



Power Electronic Systems  
Laboratory

© 2013 IEEE

IEEE Transactions on Industrial Electronics, Vol. 60, No. 10, pp. 4260-4271, October 2013

## Technological Issues and Industrial Application of Matrix Converters: A Review

L. Empringham,  
J. W. Kolar,  
J. Rodriguez,  
P. W. Wheeler,  
J. C. Clare

This material is published in order to provide access to research results of the Power Electronic Systems Laboratory / D-ITET / ETH Zurich. Internal or personal use of this material is permitted. However, permission to reprint/republish this material for advertising or promotional purposes or for creating new collective works for resale or redistribution must be obtained from the copyright holder. By choosing to view this document, you agree to all provisions of the copyright laws protecting it.



Eidgenössische Technische Hochschule Zürich  
Swiss Federal Institute of Technology Zurich

# Technological Issues and Industrial Application of Matrix Converters: A Review

Lee Empringham, *Member, IEEE*, Johann W. Kolar, *Fellow, IEEE*, Jose Rodriguez, *Fellow, IEEE*, Pat W. Wheeler, *Member, IEEE*, and Jon C. Clare, *Senior Member, IEEE*

**Abstract**—This paper presents a review of the current state of the art in terms of practical matrix converter technologies. Present solutions to the numerous technological issues and challenges faced when implementing viable matrix converters are discussed. The reported use of the matrix converters in different applications is also presented together with a review of current industrial applications.

**Index Terms**—Matrix converters.

## I. INTRODUCTION

THE MATRIX converter is an ac–ac power converter topology based mainly on semiconductor switches with minimal requirements for passive components. It consists of a matrix of bidirectional switches arranged such that any input phase can be connected to any output phase. As in the majority of cases, a three-input three-output converter will consist of a “matrix” of nine bidirectional switches, hence the term “matrix converter.” The gating of the devices is modulated to achieve the desired output voltage.

The matrix converter first appeared in the literature in a book by Gyugi and Pelly [1] in 1976 and in a journal publication by Daniels and Slattery [2] in 1978 (submitted for publication in 1976), and these both presented the direct ac–ac power circuit concept. In these publications, it was also described as a “force commutated cycloconverter.” Since then, as with many power converter topologies, work has concentrated on the derivation of modulation and control strategies. In comparison to a dc-link voltage source inverter (VSI), the modulation of the switches in the matrix converter is more difficult since three changing voltages can be used for the modulation. Methods analogous to VSI modulation strategies which use only the most positive and negative available voltages are presented in [3].

The control and modulation of a matrix converter is a very significant research subject area, and detailed analysis is beyond the scope of this paper. It is, however, in many ways very similar to that of a traditional VSI. The difference being that the switching states of the converter do not need to be chosen based only on the desired output voltage but can also include the input current. Many modulation algorithms have been presented in the literature.

In [4], both the input current and the output voltage are taken into account, and all three available input voltages are used in the modulation of the converter. The space vector modulation (SVM) technique described in [5] and [6] has also been successfully applied to matrix converters. In [7], the SVM technique under abnormal input conditions is examined. Advanced methods such as the predictive control technique described in [8] and the sliding mode control described in [9] have also been analyzed and implemented. A generalized technique for the modulation of matrix converters is described in [10], and a modulation technique for matrix converters with any number of output phases is presented in [11].

Once the modulation algorithm functions correctly and the converter output voltage follows the demanded voltage, the implementation of current and speed control loops is exactly the same process as would be followed for a VSI inverter.

As well as the lack of bulky dc-link components, these control methods help to define some of the well-known attributes of this converter topology such as the voltage transfer ratio of 86%, sinusoidal input and output current, and controllable input power factor. Since there are no energy storage components, any power pulsations present at the output of the converter will also be present at the input of the converter. This implies that the matrix converter will not be the ideal solution for pulsed loads when the input power quality is important for the application. It is highly suited, however, to constant power loads such as sinusoidal motor drives such as induction machines or permanent-magnet synchronous machines (PMSMs).

Fig. 1 shows a schematic diagram of a three-input three-output matrix converter. A detailed review of the characteristics of the matrix converter is described in [12]. Since this type of converter is completely reversible and bidirectional, the input and output can be arbitrarily defined according to the application. In this example, the voltage-stiff supply is defined as the input, and the current-stiff motor is defined as the output, but this can be reversed depending on the application. While, at first glance, the matrix converter seems to be a more complicated concept when compared to a VSI, it has been shown in [13] that the VSI can be thought of as a subset of the

Manuscript received January 25, 2011; revised April 23, 2011 and July 15, 2011; accepted August 17, 2011. Date of publication September 4, 2012; date of current version May 16, 2013.

L. Empringham, P. W. Wheeler, and J. C. Clare are with the Power Electronics, Machines and Control Group, Faculty of Engineering, The University of Nottingham, Nottingham NG7 2RD, U.K. (e-mail: lee.empringham@nottingham.ac.uk; pat.wheeler@nottingham.ac.uk; jon.clare@nottingham.ac.uk).

J. W. Kolar is with the Power Electronic Systems Laboratory, 8092 Zurich, Switzerland (e-mail: kolar@lem.ee.ethz.ch).

J. Rodriguez, is with the Department of Electronics Engineering, Universidad Tecnica Federico Santa Maria, Valparaíso 2390123, Chile (e-mail: jrp@usm.cl).

Color versions of one or more of the figures in this paper are available online at <http://ieeexplore.ieee.org>.

Digital Object Identifier 10.1109/TIE.2012.2216231

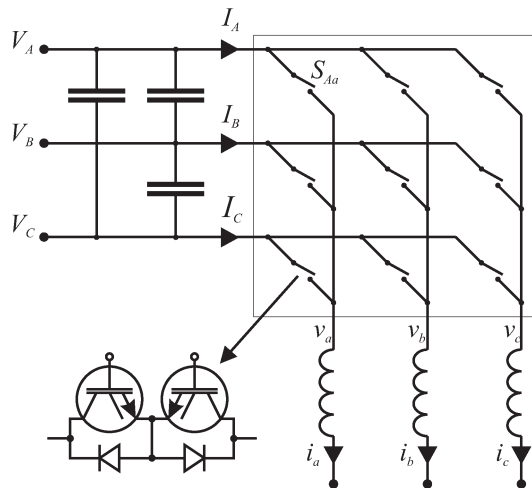

Fig. 1. Schematic representation of a three-input-phase three-output-phase direct matrix converter.

matrix converter, and techniques to modulate and control one can be used on the other.

This paper will present a review of present industrial applications of the matrix converter and will address the solutions to the technological issues and barriers surrounding the design, construction, and implementation of such converters.

## II. BIDIRECTIONAL SWITCH TECHNOLOGY

The main building block of the matrix converter is the bidirectional semiconductor switch. A single device that can both conduct current in each direction and block voltage in both directions is currently not commercially available, although some work has been reported into the monolithic bidirectional switch in [14]–[16], and various bidirectional insulated gate bipolar transistor (IGBT) structures were presented in [17]. The following section will describe common arrangements used to generate the necessary bidirectional switches.

### A. Switch Technologies

In the infancy of the research into matrix converters, the bipolar junction transistor was the most commonly used controlled switch [18]. Other options include the MOSFET, the gate turnoff thyristor (GTO), and the integrated gate commutated thyristor (IGCT). The use of the MOSFET is typically restricted to low-power applications due to the limited blocking voltages available, and the limited switching frequency of both the GTO and the IGCT limits their use in matrix converter applications.

Other power semiconductor devices include the MOS turnoff thyristor (MTO) described in [19] and the MOS controlled thyristor (MCT) described in [20]. The MTO, like the GTO, was designed for high-power applications, and similar limitations on switching frequency exist; nevertheless, matrix converters using MTOs have been reported [21] together with the lower power MCTs [22].

Most matrix converter applications currently use IGBT devices and diodes to create the power circuit. The reverse block-

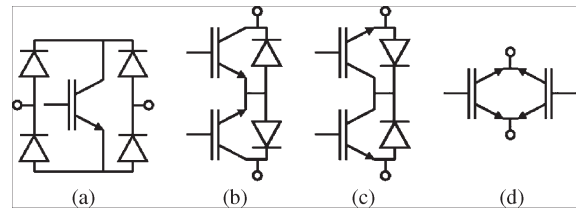

Fig. 2. Possible bidirectional switch arrangements. (a) DB arrangement. (b) CE arrangement. (c) CC arrangement. (d) RB-IGBT arrangement.

ing IGBT (RB-IGBT) [23]–[25] is also gaining popularity since antiparallel diodes can be eliminated from the converter.

### B. Active Device Arrangements

Bidirectional switches must be constructed from available unidirectional devices. Fig. 2 shows some typical arrangements. The diode bridge (DB) arrangement uses only one active device, but the conduction losses are higher than other arrangements since the current flows through one switch and two diodes. The common emitter (CE) and common collector (CC) arrangements allow the current direction to be controlled, and this allows greater flexibility when performing the commutation of current between input phases. Arrangement (d) is for devices that can block voltage in both directions such as the RB-IGBT or MTO.

The simple DB arrangement requires only one gate drive per bidirectional switch but suffers the highest conduction losses of all the arrangements. The fact that there is only one controllable device per switch also means that advanced commutation techniques which remove the need for snubbers cannot be used such as those described in [3] and [26]. It does, however, offer simpler control and less gate drive requirements than the other options. Matrix converter prototypes have been built using this arrangement [18].

The RB-IGBT arrangement together with the CC configuration only requires six isolated gate drive power supplies in contrast to the nine required by the CE arrangement. Since the CE arrangement is modular in structure and requires only one power supply per bidirectional switch, it may be better for high-power converters where the physical size of the converter becomes significant and the stray inductance of bus bars may prevent the use of the six isolated power supply methods.

### C. Matrix Converter Reliability

The reliability of matrix converters is often intuitively thought of as being less than that of more traditional industrial drive topologies such as the rectifier–VSI or the back-to-back pulse width modulated (PWM) rectifier–inverter topologies because of the increase in the number of semiconductors used. Textbook reliability studies have shown, however, in [27] and [28] that this is not necessarily the case. If a matrix converter using a typical bidirectional switch arrangement such as the one shown in Fig. 2(b) and (c) is assumed, 18 IGBTs and 18 diodes are needed together with associated gate driver circuitry, compared to the six IGBTs and 12 diodes of the rectifier–VSI

drive and the 12 diodes and IGBTs of the back-to-back VSI converter. The failure rate for the matrix converter is increased due to the increased number of devices, but the voltage stress to which the matrix converter devices are submitted is much reduced compared to the VSI topologies. The IGBT blocking voltage would typically be around 590 V for the rectifier-VSI and 750 V for the back-to-back VSI for a 400-V line-line system, whereas devices in a matrix converter would only be subjected to a half-wave sinusoidal voltage with peak-input line-to-line magnitude. In [29] and [30], the intrinsic reliability of matrix converters due to thermal cycling of the power devices when comparing conventional matrix converters, indirect matrix converters, and VSIs has been studied. The conclusion as to which is the most reliable topology is mainly dependent on the application for which the converter will be used. As with many other converter topologies, the matrix converter reliability can be improved using robust failure detection algorithms, modified circuit arrangements, and postfailure modulation strategies. In [31], a fast technique to detect and localize a faulty power device using a correlation of the protective clamp circuit current and the output phase currents is presented. The converter then uses a fourth leg of the converter to continue the operation of the motor. In [32], a multistage fault diagnosis strategy based on the output current magnitudes and the input voltage sector is presented together with a modulation strategy to avoid the use of the failed device. Fault-tolerant four-leg detection and modulation schemes are presented in [33]. These strategies can be employed to continue satisfactory operation after a failure has occurred.

### III. POWER MODULE IMPLEMENTATION

Implementing the power circuit for a matrix converter is not as straightforward as it would typically be for a VSI. This is due to a lack of available power modules arranged in a suitable configuration. Modules to create VSI converters have been available for many years. Prototype matrix converters, however, have often been constructed using discrete IGBTs and diodes which makes the demonstration of any potential space savings difficult. Some bespoke power modules, built for particular projects or research demonstrators, are reported in the literature. Some of these modules are now commercially available.

#### A. Early Experimental Matrix Converter Power Modules

If more semiconductors could be integrated into a single module, an improvement in the case to semiconductor ratio would result, and hence, a higher power density would be possible. Several projects have been carried out in recent years that take advantage of the higher levels of integration that VSI structures have enjoyed for many years, in order to fully demonstrate the size advantage of the matrix converter.

One of the first reported matrix converter power modules is described in [34]. Here, a 100-A 1200-V module contains three CC-arranged bidirectional switches, connected to form one output leg of a three-input three-output direct matrix converter. This module was designed and manufactured by EUPEC.

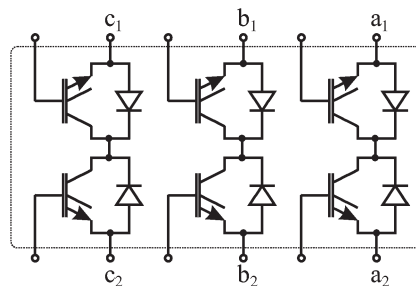

Fig. 3. Schematic diagram of the power module containing three CC-arranged bidirectional switches.

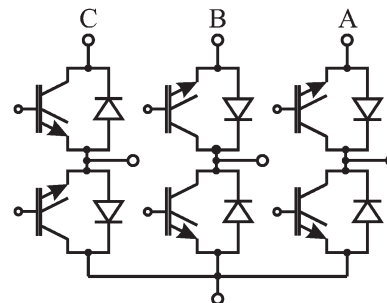

Fig. 4. Schematic diagram of the power module containing two CC-arranged bidirectional switches and one CE bidirectional switch.

Fig. 3 shows a schematic representation of the developed power module.

In [35], techniques to create a low-cost matrix converter power module are discussed. An interesting arrangement of CE and CC bidirectional switches described in [36] is suggested together with a method of reducing the number of isolated gate drive circuits to three. Fig. 4 shows the internal arrangement of the proposed power modules. It consists of one CE-arranged bidirectional switch and two CC bidirectional switches. The midpoints of the bidirectional switches can be used together with six external diodes to form a clamp circuit. A traditional clamp circuit requires 12 diodes, but the arrangement of CC and CE switches in the power module allows some of the power diodes within the module to form part of the clamp circuit.

The same authors, in a later paper and in collaboration with Danfoss Drives, report an experimental traditional CC-arranged 25-A 1200-V three-phase-to-single-phase module used to integrate the converter into an industrial induction motor [37].

One of the most widely used matrix converter modules was developed by EUPEC/Infineon and was reported in [38]. A standard Econo3 sized module was used to implement a CC-arranged full three-phase-to-three-phase matrix converter rated at 30 A and 1200 V. Many experimental and demonstration projects used this module as the basis for the matrix converter [39]–[41]. It offers a very high level of integration and power density, although with a power module of this rating, the auxiliary circuitry, such as gate drives, power supplies, and controllers, becomes a large part of any converter volume. A full schematic diagram of the EUPEC matrix converter module is shown in Fig. 5.

In [42], enough devices to create a third of a matrix converter were integrated into a single module by International Rectifier Corporation Italy. The EMP-M50P12 was rated at

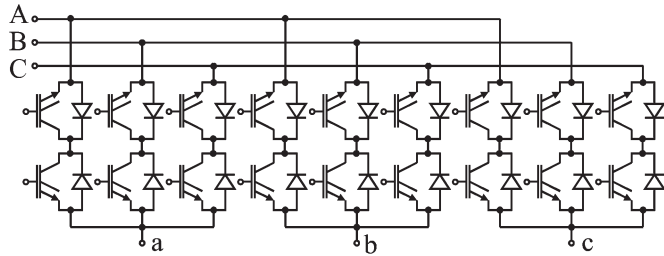

Fig. 5. Schematic diagram of the EUPEC power module containing nine CC-arranged bidirectional switches, arranged to form a complete three-input three-output matrix converter.

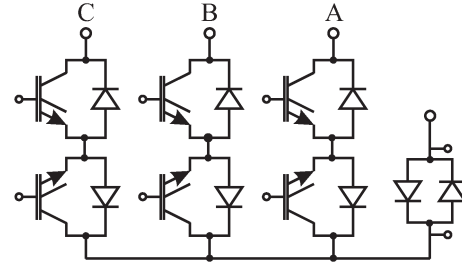

Fig. 7. Schematic diagram of the internal layout of the three CE-arranged bidirectional switches to form one output leg of a matrix converter including the antiparallel output diodes.

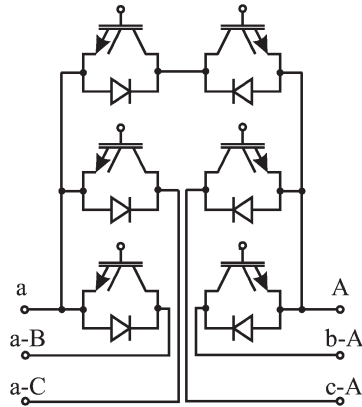

Fig. 6. Schematic diagram of the EMP-M50P12 power module containing one third of the devices needed for a complete 3 by 3 matrix converter.

50 A and 1200 V. The internal arrangement is different from the typical single output phase arrangement in that it contains three IGBTs connected to one input phase and three IGBTs connected to an output phase. This was done so that the external PCB arrangement could be simplified, and in this way, each power module requires only two isolated power supplies. It is reported that both the collector and emitter connections were available, and this enabled overcurrent protection based on  $V_{ce}$  to be implemented. These connections are not available on all modules. A schematic diagram of the internal layout of the power module is shown in Fig. 6.

A project to integrate a matrix converter onto an electromechanical actuator (EMA) for aerospace applications was reported in [43]. The power module contained all of the IGBTs and reverse diodes to create a single output leg of a direct matrix converter rated at 600 V and 300 A. The module, manufactured by Semelab for the Electrically Driven Advanced Actuator System (EDAAS) project, also contained antiparallel low-loss Schottky diodes in the output connection to enable the robust detection of the output current direction in order to perform the current commutation. A schematic of the internal configuration of the module is shown in Fig. 7. It was also constructed using an AISiC baseplate for improved reliability. A photograph of the module can be seen in Fig. 8. This module later became the Semelab SML300MAT06; see Table I.

A 100-A 1200-V power module using RB-IGBTs was demonstrated in [24]. The module was jointly developed by Powerex Corporation, USA, and Mitsubishi Electric Power Semiconductor Device Works, Japan, and contains all of the devices necessary to create a three-phase-to-three-phase con-



Fig. 8. Semelab 300-A 600-V 3 × bidirectional switch module developed for the EDAAS project.

TABLE I  
PRESENTLY AVAILABLE COMMERCIAL POWER MODULES  
ARRANGED TO CONSTRUCT MATRIX CONVERTERS

Characteristics	Model	Arrangement & No. of Switches	Manufacturer
1200V 35A	FM35R12KE3[38]	CC 9	Eupec
1200V 50A	FIO50-12BD	DB 1	Ixys
1200V 50A	18MB150W-120A	RBIGBT 9	Fuji
1200V 60A	SK60GM123	CE 1	Semikron
1200V 60A	IXRH50N120	RBIGBT 1	Ixys
1000V 60A	IXRH50N100	RBIGBT 1	Ixys
600V 100A	18MB1100W-060A	RBIGBT 9	Fuji
1200V 100A	18MB1100W-120A	RBIGBT 9	Fuji
1200V 150A	SML150MAT12	CE 3	Semelab
600V 200A	18MB1200W-060A	RBIGBT 9	Fuji
1200V 200A	DIM200MBS12-A[48]	CE 1	Dynex
600V 300A	SML300MAT06[43]	CE 3	Semelab
1700V 400A	DIM400PBM17	CE 1	Dynex
1700V 600A	DIM600EZM17-E000[45]	CE 3	Dynex

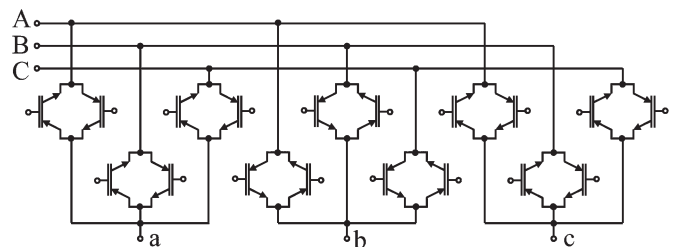

Fig. 9. Schematic diagram of the internal layout of the RB-IGBT-arranged bidirectional switches to form a three-input three-output matrix converter including the antiparallel output diodes.

verter. Similar modules have also been described in [44]. A schematic diagram showing the internal connection of the RB-IGBTs to form the power module is shown in Fig. 9.

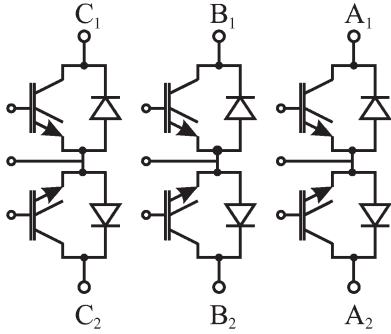

Fig. 10. Schematic diagram of the internal circuit of the DIM600EZM17-E000. It contains three CE-arranged 1700-V 600-A bidirectional switches to form one output leg of a matrix converter.

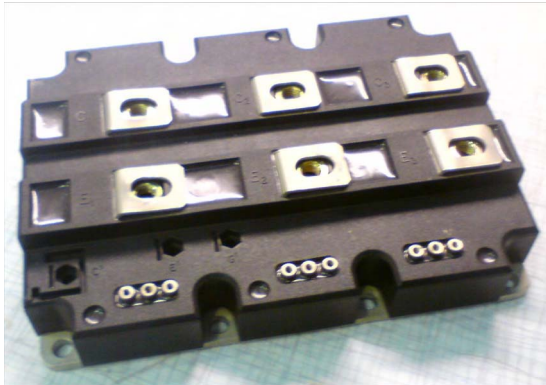

Fig. 11. Dynex E-type 600-A 1700-V 3x bidirectional switch module.

In [45], a 100-kW matrix converter prototype is described. The three-phase-to-three-phase converter is constructed using three power modules, each containing three bidirectional switches rated at 1700 V and 600 A. The power module was built by Dynex Semiconductor using a standard E-type package with a modification in the internal bus structure to implement the CE-arranged bidirectional switches. This module has also been implemented using 500-A silicon carbide antiparallel diodes. A schematic diagram of the internal circuit arrangement of the Dynex DIM600EZM17-E000 described earlier is shown in Fig. 10. Fig. 11 shows a photograph of the module.

The developments described earlier have concentrated solely on the power module arrangement and implementation. Research into incorporating intelligent-power-module functionality such as gate drive and control into the power modules was carried out in [34] and [46]. Related to the concept of integration of control electronics, the work carried out in [47] was aimed at the analysis of the electromagnetic fields present in a resonant bidirectional switch module and the creation of a low field area within the switch. This magnetic null area was intended to be used for sensitive low voltage control electronics.

#### B. Commercially Available Matrix Converter Power Modules

Recent interest in matrix converter technology and some of the previously mentioned prototype/demonstrator projects has resulted in a few manufacturers offering commercial power modules for matrix converter applications. These range from individual bidirectional switches to three-phase-to-single-phase

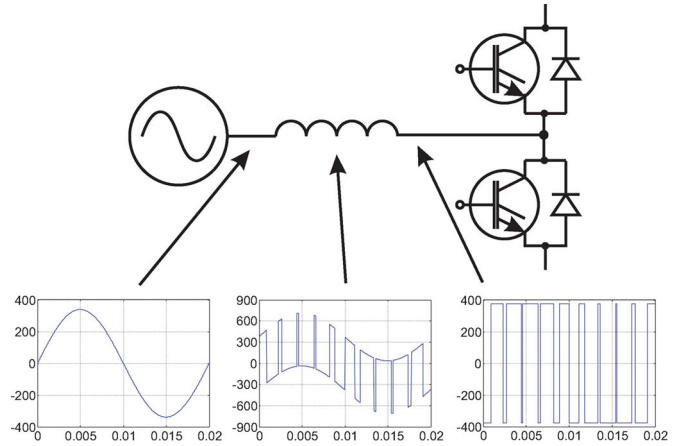

Fig. 12. Illustrative filter voltages for a PWM rectifier ( $Y$ -axes in volts and  $X$ -axes in seconds).

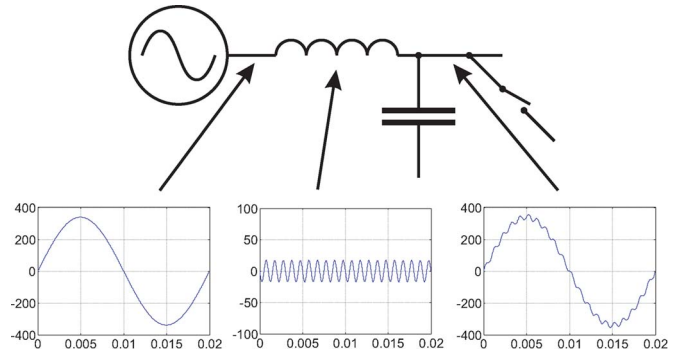

Fig. 13. Illustrative filter voltages for a matrix converter ( $Y$ -axes in volts and  $X$ -axes in seconds).

output modules to entire three-phase-to-three-phase converters. Table I shows a list of commercially available modules, although not all of them are “off-the-shelf” components.

## IV. DESIGN AND CONSTRUCTIVE ASPECTS

### A. Input Filter Considerations/Tradeoff

In a typical motor drive application, a simple  $LC$  input filter is often used by different converter topologies to reduce the switching harmonics presented to the converter supply. The size and design of this filter depends on many factors such as the following:

- 1) power quality requirements;
- 2) power system harmonic content;
- 3) converter switching frequency;
- 4) converter modulation technique.

A significant advantage of a matrix converter topology is in the input filter size. A typically sized input inductor for a matrix converter will almost always be smaller than the equivalently rated input inductor of a PWM rectifier. Figs. 12 and 13 illustrate this point. These figures show representative voltage waveforms on either side of the input inductor for both the PWM rectifier and the matrix converter. The PWM rectifier waveforms shown in Fig. 12 are based on a typical dc-link voltage of 750 V. The matrix converter waveforms shown in Fig. 13 are based on a 5% switching frequency ripple, and both

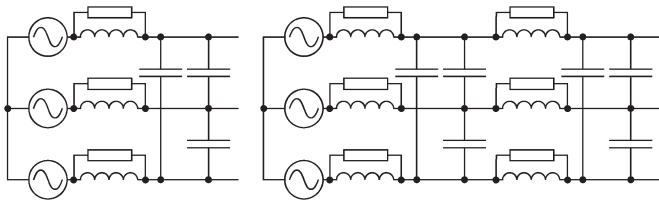

Fig. 14. Typical input filter configurations. Single stage and two stage.

systems use an input supply of 240 V Line to Neutral and a 1-kHz PWM frequency. It can be clearly seen that the ripple voltage across the inductors are very different, and if the same input current ripple is required in both cases, a much larger value of inductance will be required for the PWM rectifier. This leads to a more costly and bulky input inductor for the PWM rectifier.

The choice of input filter arrangement and size depends mostly on the application requirements, but some guidelines have been presented in the literature. The basic strategy is to provide a filter that provides a voltage-stiff port to the matrix circuit and attenuates the switching frequency components enough to satisfy the power quality requirements while avoiding any resonance of the input filter. The input filter resonance can be excited by either supply-side harmonics or harmonics generated by the matrix converter modulation itself. Typical single- and two-stage input filter arrangements are shown in Fig. 14.

Detailed analysis of the harmonic performance of different modulation techniques is presented in [49], and the harmonic effects of different arrangements of the switching patterns for SVM are shown in [50]. In general, supply-side harmonics are of a much lower frequency than the switching frequency harmonics which can help to decouple the two when designing the input filter; this, however, is not always true and is considerably more challenging in frequency wild power systems such as those found on modern aircraft or in variable-speed generator applications. Further analysis of the input filter design compared to rectifier-VSI topologies can be found in [51]. Further work on input filter design and limitations was also described in [52].

There are also decisions to be made in the actual physical implementation of the filter once the theoretical values of inductance, capacitance, and resistance have been finalized. The input capacitors can be arranged in either a Delta or Star arrangement. The advantage in the Delta arrangement is that capacitances of 1/3 of that of the Star arrangement can be used whereas higher voltages must be sustained. The input inductor can be realized as a three-phase reactor or three individual inductances. The three-phase reactor offers a smaller solution but little common mode attenuation. Although this is not necessary, it may be important if an electro-magnetic interference (EMI) filter is to be integrated.

### B. Power Circuit Layout

As with all converter topologies which include switching devices, a voltage-stiff port needs to be connected via the switches to a current-stiff port. In this discussion, the input will be thought of as the voltage-stiff (capacitive) port and the output

will be thought of as the inductive current-stiff port, as shown in Fig. 1. This is analogous to the VSI in that a dc-link capacitor provides the input to the inverter stage and the inductive load; typically, an induction motor is connected to the output.

Since the typical input filter of the matrix converter consists of an  $LC$  arrangement, the capacitance generally forms the voltage-stiff input of the power circuit. It is important that the parasitic inductance between the input capacitors and the power stage is minimized to avoid overvoltages across the bidirectional switches during current commutation. It is for this reason that the input filter needs to be properly integrated into the power circuit using similar power planes as used in VSIs. The input filter cannot realistically be separated from the power circuit unless local capacitance is provided to assist current commutation.

Analysis of the current paths at the input of the matrix converter and associated inductances of different planar bus-bar arrangements is discussed in [53].

### C. Protection

Since there are no freewheeling paths within the matrix converter circuit for the inductive load current, the protection of the main power devices due to overvoltages needs to be addressed. Overvoltages can occur due to an open circuit of the load. This may be caused by commutation failure, device/gate drive failure, or, simply, a turnoff of the drive.

Schemes have been suggested, which use the matrix converter to create freewheel paths so that the inductive load energy can be transferred back to the supply, such as those described in [54] and [55]. These techniques have the advantage that no extra protection devices are necessary, but the method cannot function correctly if a failure occurs in the gate drive or devices currently used to create the freewheel paths. This method also will not work if the input supply is cut off, i.e., there would be nowhere to transfer the load energy to.

The classical method of protecting the matrix converter is to use a DB arrangement on the input and output of the converter as described in [56]. This arrangement provides a path for the inductive load current during turnoff. The size of the capacitor is typically small and can be calculated based on the load inductance, initial clamp voltage, and final clamp voltage

$$W_{\text{Load}} = \frac{1}{2}L(i_a^2 + i_b^2 + i_c^2) = \frac{3}{4}L\hat{I}^2. \quad (1)$$

The maximum load energy is calculated in (1), where  $W_{\text{Load}}$  is the energy stored in the inductance of the motor,  $L$  is the equivalent line inductance of the motor, and  $i_a$ ,  $i_b$ , and  $i_c$  are the line currents of the motor. The change in energy of the clamp capacitor from its initial voltage to its final voltage can be used to calculate the size of the capacitor and is shown in

$$W_{\text{Load}} = \frac{1}{2}C_{\text{Clamp}}(V_{\text{MAX}}^2 - V_{\text{INI}}^2) \quad (2)$$

where  $C_{\text{Clamp}}$  is the capacitance of the clamp capacitor,  $V_{\text{MAX}}$  is the maximum allowable clamp voltage, and  $V_{\text{INI}}$  is the initial clamp voltage.

The size of the clamp capacitor can be minimized with the use of an active dissipation device [41], [57]. This arrangement

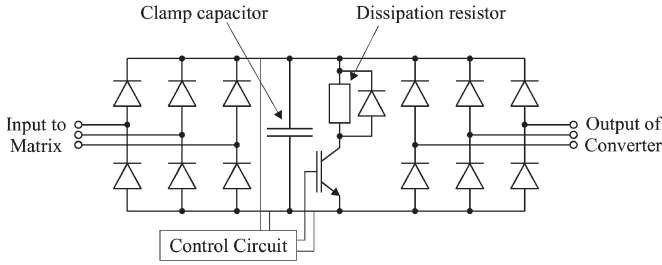

Fig. 15. High-speed DB clamp circuit with chopper.

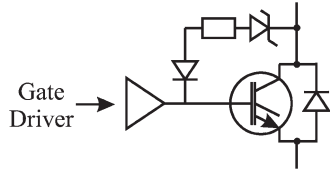

Fig. 16. Collector voltage feedback to prevent device overvoltage.

can be seen in Fig. 15. An active clamp of this type can also improve the reliability and robustness of the matrix converter power circuit. In the event of failures which repeatedly generate an open circuit of the load, the energy transferred to the clamp circuit can be dissipated, and the converter may continue to operate, albeit with a potentially poorer power quality.

Similar clamp arrangements can be used for the indirect or sparse matrix converter topologies [58]. These perform the same function described previously but using fewer diodes because of the circuit topology.

A passive protection scheme was suggested in [59] to achieve a low-cost protection solution. Here, varistors are connected across the load terminals at the output of the converter together with a similar arrangement at the input to the converter. Calculations and measurements of the energy dissipation required for different drive configurations are presented to enable the sizing of the dissipation devices. Another technique, offered in addition to this, in the same publication used a Zener diode connected to the collector of the driven IGBT in order to drive the IGBT into its active region in the event of an overvoltage in order to dissipate the excess load energy. This arrangement can be seen in Fig. 16. The clamping voltage is set by the Zener diode and has the advantage that active control circuitry is not necessary. It was shown that, under certain circumstances, only the IGBT dissipation method was necessary to protect the drive. IGBT lifetime predictions using this mode of operation could not be performed.

V. MATRIX CONVERTER APPLICATIONS/PROTOTYPES

The low voltage transfer ratio is often seen as the biggest disadvantage of a matrix converter if a like-for-like replacement for an industrial drive is required. Some attempts to address the problem on an overmodulation basis have been performed [60], but inevitably, input power quality is sacrificed in favor of output drive capability. Work based on minor topology changes, particularly using the indirect matrix converter, has been proposed in [61] at the cost of increased complexity and size.

In applications where the load motor in the drive system can be specified and appropriately selected, the voltage transfer ratio limitation is not an issue.

In motor drive where the converter is integrated with or sold with the motor, clearly, the matrix converter should have a size and a weight advantage over competing VSI technologies. Work on a 4-kW integrated matrix converter-induction machine drive was described in [37]. The design and construction of a 30-kW version was further described in [49].

The potential size and weight advantages of the matrix converter and the elevated temperature capability due to the lack of dc-link components lend themselves to aircraft applications. Several prototype aircraft actuator projects have been reported in the literature. In [62], collaboration with Smiths Aerospace led to the creation of a 7-kW matrix converter used to drive a 10 000-r/min PMSM integrated into an electrohydrostatic actuator. The matrix converter was chosen in this application because of the ability to be driven from a frequency wild supply. This prototype was based on the Infineon Economac matrix converter module.

A higher power direct drive EMA was described in [43]. Collaboration with Smiths Aerospace, which later became GE Aviation, resulted in the development of both a 20-kW integrated matrix converter and a 20-kW 10 000-r/min PMSM to create a fully integrated rudder actuator.

An indirect matrix converter drive was developed in collaboration with MOOG for an EMA application described in [63]. The same requirements for a variable frequency supply with aircraft power quality specifications were desired as per the previous two examples. The main difference in this project was the requirement to prevent the regeneration of energy back to the supply. This process can be more easily achieved using an indirect matrix converter using a suitable dissipation circuit connected to the standard protective clamp circuit. A comprehensive comparison of the conventional matrix converter, the indirect matrix converter, and the back-to-back PWM rectifier-inverter is described in [64].

A deep sea remotely operated vehicle (ROV) matrix converter drive application was the subject in [65]. The extreme pressure experienced by ROVs and the lack of large and fragile dc-link components were the reason that the matrix converter was chosen as a potential topology for the application. Research into the effects of high atmospheric pressure on the constituent parts of typical drive systems was carried out at 300 bar. The paper also investigates the use of observer-based sensorless control of a PMSM using the matrix converter.

The matrix converter has also been applied to drive the rotor circuit of a doubly fed induction generator for wind turbine applications using direct [66] and indirect matrix converters [67]. This technique has the advantage that a relatively low power four-quadrant power converter can be used to control a high-power generator system. Research into the stability of such systems is presented in [68], and the effects of rotor-side harmonics in a similar system were presented in [69].

In [70], a reduced matrix converter (three phase to two phase) was used to control a wind turbine generator and drive a single-phase transformer which was then connected through an ac rectifier to a dc transmission line. The efficiency under different



modulation and control techniques was addressed in [71] for this type of matrix converter. Further work into a novel matrix converter topology to allow the coupling of energy generation resources and the grid was recently presented in [72].

Further industrial interest is outlined in [60]. This paper highlights the characteristics of the matrix converter from a manufacturer's perspective in terms of cost, competitiveness, and size. The overmodulation performance of the matrix converter is also evaluated for applications where a direct replacement of an industrial VSI drive is required.

Matrix converters are finding application in the power supply generation area. Instead of the typical motor drive application, an output filter is used in order to provide a voltage source of the desired amplitude and frequency. This concept allows fixed voltage and frequency power supplies to be implemented and driven from variable frequency diesel generators. In [73], the issues regarding the control of the output voltage and frequency when using a resonant  $LC$  output filter under stringent power quality requirements are described. The operation of the generator at the optimum speed, particularly under lightly loaded conditions, can offer increased fuel efficiency. The application of the matrix converter in polyphase generator systems has been discussed in [74] and [75]. In this case, the matrix converter transforms not only the input frequency and voltage but also the number of phases. Since the matrix converter circuit is modular, any number of input and output phases can be implemented. Protection strategies for the matrix converter when used as a grid supply converter are discussed in [76].

A similar microturbine generation system was described in [77]. The main challenge here was the high input frequency of 2221 Hz. A new switching technique is proposed in order to minimize the number of switching events while maintaining harmonic performance.

An interesting use of a matrix converter using only unidirectional switches was described in [78]. Here, a matrix of nine unidirectional switches was used to drive an induction machine. A dc offset was demanded for each of the output phases to enable a sinusoidal component to be present at the output of the converter. Two methods to then remove the effect of the converter output dc component were suggested in order to maintain the performance of the induction machine. Fig. 17 shows the arrangement of the unidirectional matrix converter, input filter, and specially wound induction machine.

The main advantage of this technique was that the number of IGBTs and diodes is reduced to 50% of those required by a conventional three-phase to three-phase matrix converter and that, since the current can only flow in one direction, the current commutation process becomes inherently safe. Another application of a unidirectional matrix converter was to drive a five-phase fault-tolerant brushless dc (BLDC) motor for the pump in an electrohydrostatic actuator [79]. A unidirectional matrix converter was also used to drive a switched reluctance motor (SRM) in [80]. The power circuit consists of six output phases. Each winding on the SRM is galvanically isolated from the others and is driven by two of the output phases of the converter. In one of these output phases, the devices are arranged such that current can only flow in one direction from the supply to the motor, and in the other phase, current can

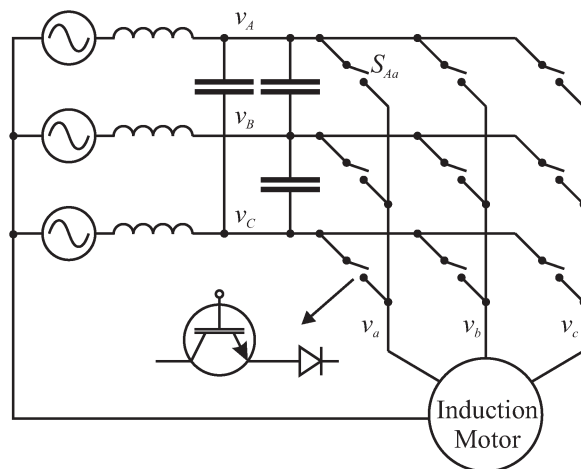

Fig. 17. Diagram of the unidirectional matrix converter feeding an induction machine.

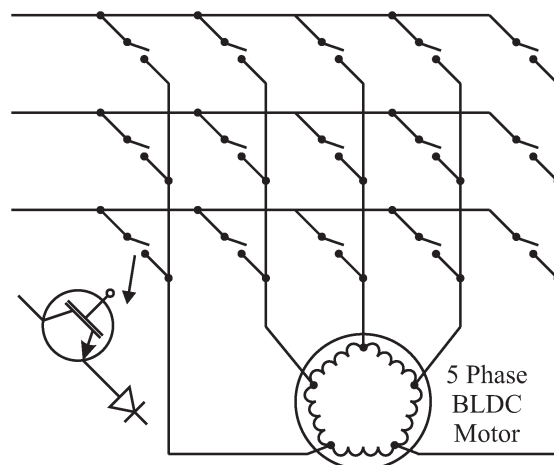

Fig. 18. Diagram of power circuit arrangement for the five-phase unidirectional matrix converter feeding a PMSM.

flow from the motor winding to the supply. The switching of the converter is then modulated to deliver the desired output voltage and therefore control the current in the motor. The main disadvantage of the aforementioned unidirectional matrix converter topologies is that the input current quality is very poor. The “pulsed power” nature of the SRM and the BLDC further increase the disturbance seen on the input currents of the converters. This is due to the fact that there are no energy storage components within the matrix converter circuit and any power disturbances at the output will inevitably result in a disturbance at the input. Figs. 18 and 19 show diagrams of the circuit arrangement for the unidirectional matrix converters driving the five-phase BLDC motor and the three-phase SRM.

## VI. PRODUCTS IN THE MARKET

To date, the only drive manufacturers to offer matrix converter products are Yaskawa and Fuji Electric Systems. Both series are aimed at the general drives market with emphasis on the energy saving potential with the inherent regeneration capability.

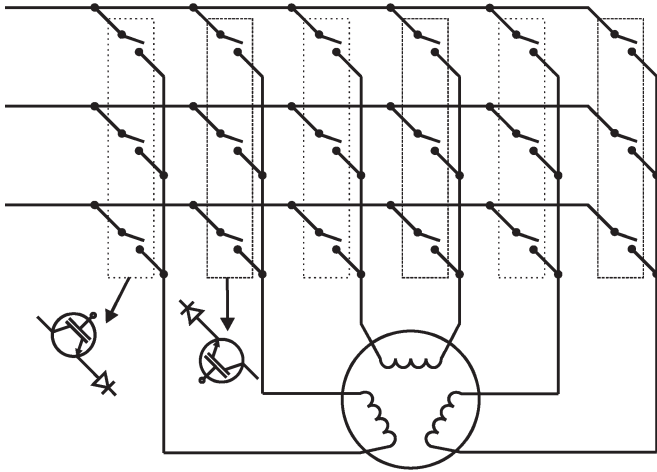

Fig. 19. Diagram of power circuit arrangement for the six-phase unidirectional matrix converter feeding a three-phase SRM.

Fuji Electric Systems has developed the FRENIC-MC series of matrix converters which are available in 15- and 30-kW versions with a 230-V input and 15-, 30-, and 45-kW versions using a 480-V input [81].

Yaskawa currently advertises two ranges of converters for use on low voltage power systems of either 230- or 480-V input. The AC7 converter is available in four power levels ranging from 7.5 to 60 hp for a 230-V input and in five power levels ranging from 10 to 125 hp for the 480-V option. The AC7 offers all of the typical features that one would expect from a programmable industrial vector drive with some additional benefits. It is a fully regenerative drive with a 150% overload capability in either direction for 1 min and with a maximum input current total harmonic distortion of 7%. Since it is fully regenerative, it is advertised as an energy-reducing technology for applications such as lifts, hoists, conveyors, and escalators. All external add-on units such as external braking resistors are eliminated in the AC7.

Yaskawa also offers a range of medium-voltage matrix converter drives. The FSDrive-MX1S is aimed at two voltage systems, 3 and 6 kV. A major selling point is again the potential efficiency savings in using an inherently regenerative drive. The power level of the different models in the MX1S series range from 200 kW to 3 MW for a 3-kV system and from 400 kW to 6 MW for the 6-kV version. The power factor is always maintained to be greater than 0.95 with an efficiency of 98%.

These products can be seen as the start of a growing range of industrial products from other companies. As more companies invest in matrix converter technology, it will encourage other drives manufacturers to follow.

## VII. CONCLUSION/FUTURE TRENDS

The matrix converter offers many potential benefits to the power converter industry. It will not be the best solution for all uses, but it offers significant advantages for many different applications. This paper has reviewed the present matrix converter work from the perspective of implementing a realistic converter. While, for many years, it seemed that the matrix converter would be restricted to a small range of niche areas, the

commitment to invest in matrix converters from several large industrial drives manufacturers may see the start of an industry-wide uptake of this technology.

Cutting-edge research in power converters is currently aimed at the use of wide-bandgap materials such as gallium nitride (GaN) and silicon carbide (SiC). These materials offer potential advantages over silicon devices, and research into the use of these devices in prototype power converters is being reported. Potential advantages include the following:

- 1) faster switching—lower switching loss;
- 2) higher temperature operation—higher power density;
- 3) higher voltage structures.

Where these advantages may seem ideal and exactly what power electronics researchers have been looking for, considerable research needs to be carried out in order to realize these potentials. The decrease in switching losses due to the promised increase in switching speed cannot be presently implemented due to the associated problems caused to the EMI performance of the drive. Similarly, present packaging technology is the limiting factor for the increased temperature operation of these new devices. A more integrated approach to power converter design will be needed in the future which takes packaging, thermal management, circuit layout, and EMI performance into account at the same time. In this way, optimized structures which minimize commutation paths and conducted EMI while obtaining high-temperature operation will be attained. Some examples of the use of SiC devices in direct converter topologies can be found in [82] and [83].

## REFERENCES

- [1] L. Gyugi and B. Pelly, *Static Power Frequency Changers: Theory, Performance and Applications*. New York: Wiley, 1976.
- [2] A. Daniels and D. Slattery, "New power converter technique employing power transistors," *Proc. IEE*, vol. 125, no. 2, pp. 146–150, Feb. 1978.
- [3] J. Oyama, T. Higuchi, E. Yamada, T. Koga, and T. Lipo, "New control strategy for matrix converter," in *Proc. IEEE PESC/IEEE Power Electron. Spec. Conf.*, Jun. 1989, vol. 1, pp. 360–367.
- [4] A. Alesina and M. Venturini, "Analysis and design of optimum-amplitude nine-switch direct ac-ac converters," *IEEE Trans. Power Electron.*, vol. 4, no. 1, pp. 101–112, Jan. 1989.
- [5] L. Huber and D. Borzjevic, "Space vector modulation with unity input power factor for forced commutated cycloconverters," in *Conf. Rec. IEEE IAS Annu. Meeting*, Oct. 1991, vol. 1, pp. 1032–1041.
- [6] D. Casadei, G. Serra, A. Tani, and L. Zarri, "Matrix converter modulation strategies: A new general approach based on space-vector representation of the switch state," *IEEE Trans. Ind. Electron.*, vol. 49, no. 2, pp. 370–381, Apr. 2002.
- [7] X. Wang, H. Lin, H. She, and B. Feng, "A research on space vector modulation strategy for matrix converter under abnormal input-voltage conditions," *IEEE Trans. Ind. Electron.*, vol. 59, no. 1, pp. 93–104, Jan. 2012.
- [8] J. Rodriguez, J. Espinoza, M. Rivera, F. Villarroel, and C. Rojas, "Predictive control of source and load currents in a direct matrix converter," in *Proc. IEEE ICIT*, 2010, pp. 1826–1831.
- [9] M. Hamouda, F. Fnaiech, K. Al-Haddad, and H. Kanaan, "Matrix converter control: A sliding mode approach," in *Proc. IEEE IECON*, Nov. 2004, vol. 3, pp. 2295–2300.
- [10] H. Hojabri, H. Mokhtari, and L. Chang, "A generalized technique of modeling, analysis, and control of a matrix converter using SVD," *IEEE Trans. Ind. Electron.*, vol. 58, no. 3, pp. 949–959, Mar. 2011.
- [11] S. Ahmed, A. Iqbal, and H. Abu-Rub, "Generalized duty-ratio-based pulsewidth modulation technique for a three-to-phase matrix converter," *IEEE Trans. Ind. Electron.*, vol. 58, no. 9, pp. 3925–3937, Sep. 2011.
- [12] P. Wheeler, J. Rodriguez, J. Clare, L. Empringham, and A. Weinstein, "Matrix converters: A technology review," *IEEE Trans. Ind. Electron.*, vol. 49, no. 2, pp. 276–288, Apr. 2002.

- [13] D. G. Holmes and T. A. Lipo, "Implementation of a controlled rectifier using ac-ac matrix converter theory," *IEEE Trans. Power Electron.*, vol. 7, no. 1, pp. 240–250, Jan. 1992.
- [14] R. Sittig and F. Heinke, "Monolithic bidirectional switch, part I: Device concept," *Solid State Electron.*, vol. 44, no. 8, pp. 1387–1392, Aug. 2000.
- [15] F. Heinke and R. Sittig, "Monolithic bidirectional switch, part II: Simulation of device characteristics," *Solid State Electron.*, vol. 44, no. 8, pp. 1393–1398, Aug. 2000.
- [16] F. Heinke and R. Sittig, "The monolithic bidirectional switch (MBS) in a matrix converter application," in *Proc. IPSPD*, 2001, pp. 367–371.
- [17] N. Luther-King, M. Sweet, O. Spulber, K. Vershinin, M. De Souza, and E. Narayanan, "MOS control device concepts for ac-ac matrix converter applications: The HCD concept for high-efficiency anode-gated devices," *IEEE Trans. Electron Devices*, vol. 52, no. 9, pp. 2075–2080, Sep. 2005.
- [18] C. Neft and C. Schauder, "Theory and design of a 30-hp matrix converter," in *Conf. Rec. IEEE IAS Annu. Meeting*, Oct. 1988, vol. 1, pp. 934–939.
- [19] A. Huang, Y. Li, K. Motto, and B. Zhang, "MTO thyristor: An efficient replacement for the standard GTO," in *Conf. Rec. IEEE IAS Annu. Meeting*, 1999, vol. 1, pp. 364–372.
- [20] H. Mehra, "Applications of MOS controlled (MCT) and MOS turn-off (MTO) thyristors," in *Proc. IEEE Power Eng. Soc. Summer Meet.*, 2000, vol. 2, pp. 1219–1222.
- [21] T. Podlesak, J. Tuttle, P. Wheeler, and L. Empringham, "Matrix converter using MOS turn-off thyristors," in *Conf. Rec. 24th Int. Power Modulator Symp.*, 2000, pp. 107–110.
- [22] K. Kerris, P. Wheeler, J. Clare, and L. Empringham, "Implementation of a matrix converter using p-channel MOS-controlled thyristors," in *Proc. 8th Int. Conf. (IEE Conf. Publ. No. 475) Power Electron. Variable Speed Drives*, 2000, pp. 35–39.
- [23] S. Bernet, T. Matsuo, and T. Lipo, "A matrix converter using reverse blocking NPT-IGBTs and optimized pulse patterns," in *Proc. IEEE PESC/IEEE Power Electron. Spec. Conf.*, Jun. 1996, vol. 1, pp. 107–113.
- [24] E. Motto, J. Donlon, M. Tabata, H. Takahashi, Y. Yu, and G. Majumdar, "Application characteristics of an experimental RB-IGBT (reverse blocking IGBT) module," in *Conf. Rec. IEEE IAS Annu. Meeting*, 2004, vol. 3, pp. 1540–1544.
- [25] C. Klumpner and F. Blaabjerg, "Using reverse-blocking IGBTs in power converters for adjustable-speed drives," *IEEE Trans. Ind. Appl.*, vol. 42, no. 3, pp. 807–816, May/June 2006.
- [26] N. Burany, "Safe control of four-quadrant switches," in *Conf. Rec. IEEE IAS Annu. Meeting*, Oct. 1989, vol. 1, pp. 1190–1194.
- [27] P. Wheeler, J. Clare, L. de Lillo, K. Bradley, M. Aten, C. Whitley, and G. Towers, "A comparison of the reliability of a matrix converter and a controlled rectifier-inverter," in *Proc. Eur. Conf. Power Electron. Appl.*, 2005, p. 7.
- [28] P. Wheeler, J. Clare, L. de Lillo, K. Bradley, M. Aten, C. Whitley, and G. Towers, "A reliability comparison of a matrix converter and an 18-pulse rectifier for aerospace applications," in *Proc. EPE-PEMC*, Sep. 1, 2006, pp. 496–500.
- [29] L. Wei, R. Lukaszewski, and T. Lipo, "Analysis of power-cycling capability of IGBT modules in a conventional matrix converter," *IEEE Trans. Ind. Appl.*, vol. 45, no. 4, pp. 1443–1451, Jul./Aug. 2009.
- [30] L. Wei, T. Lipo, and R. Lukaszewski, "Comparison of IGBT cycling capabilities for different ac/ac topologies," *IEEE Trans. Ind. Appl.*, vol. 46, no. 6, pp. 2475–2483, Nov./Dec. 2010.
- [31] S. Khwan-on, L. de Lillo, L. Empringham, and P. Wheeler, "Fault-tolerant matrix converter motor drives with fault detection of open switch faults," *IEEE Trans. Ind. Electron.*, vol. 59, no. 1, pp. 257–268, Jan. 2012.
- [32] K. Nguyen-Duy, T.-H. Liu, D.-F. Chen, and J. Hung, "Improvement of matrix converter drive reliability by online fault detection and a fault-tolerant switching strategy," *IEEE Trans. Ind. Electron.*, vol. 59, no. 1, pp. 244–256, Jan. 2012.
- [33] S. Kwak, "Four-leg-based fault-tolerant matrix converter schemes based on switching function and space vector methods," *IEEE Trans. Ind. Electron.*, vol. 59, no. 1, pp. 235–243, Jan. 2012.
- [34] J. Chang, T. Sun, A. Wang, and D. Braun, "Compact ac-ac converter using 3-in-1 IBPMs and adaptive commutation," in *Proc. IEEE Int. Conf. PEDS*, 1999, vol. 1, pp. 438–443.
- [35] C. Klumpner, P. Nielsen, I. Boldea, and F. Blaabjerg, "New steps towards a low-cost power electronic building block for matrix converters," in *Conf. Rec. IEEE Ind. Appl. Conf.*, 2000, vol. 3, pp. 1964–1971.
- [36] P. Nielsen, F. Blaabjerg, and J. Pedersen, "Novel solutions for protection of matrix converter to three phase induction machine," in *Conf. Rec. IEEE IAS Annu. Meeting*, Oct. 1997, vol. 2, pp. 1447–1454.
- [37] C. Klumpner, P. Nielsen, I. Boldea, and F. Blaabjerg, "A new matrix converter motor (MCM) for industry applications," *IEEE Trans. Ind. Electron.*, vol. 49, no. 2, pp. 325–335, Apr. 2002.
- [38] M. Hornkamp, M. Loddenkoetter, M. Muenzer, O. Simon, and M. Bruckmann, "EconoMAC the first all-in-one IGBT module for matrix converters," in *Proc. PCIM*, 2001, pp. 1–6.
- [39] O. Simon, J. Mahlein, M. Muenzer, and M. Bruckmann, "Modern solutions for industrial matrix-converter applications," *IEEE Trans. Ind. Electron.*, vol. 49, no. 2, pp. 401–406, Apr. 2002.
- [40] P. Wheeler, J. Clare, M. Apap, L. Empringham, C. Whitley, and G. Towers, "Power supply loss ride-through and device voltage drop compensation in a matrix converter permanent magnet motor drive for an aircraft actuator," in *Proc. IEEE PESC/IEEE Power Electron. Spec. Conf.*, 2004, vol. 1, pp. 149–154.
- [41] J. Andreu, J. De Diego, I. de Alegria, I. Kortabarria, J. Martin, and S. Ceballos, "New protection circuit for high-speed switching and start-up of a practical matrix converter," *IEEE Trans. Ind. Electron.*, vol. 55, no. 8, pp. 3100–3114, Aug. 2008.
- [42] D. Casadei, G. Serra, A. Trentin, L. Zarri, and M. Calvini, "Experimental analysis of a matrix converter prototype based on new IGBT modules," in *Proc. IEEE ISIE*, 2005, vol. 2, pp. 559–564.
- [43] L. de Lillo, L. Empringham, P. Wheeler, J. Clare, and K. Bradley, "A 20 kW matrix converter drive system for an electro-mechanical aircraft (EMA) actuator," in *Proc. Eur. Conf. Power Electron. Appl.*, 2005, p. 6.
- [44] D. Zhou, K. Sun, L. Huang, and K. Sasagawa, "A novel commutation method of matrix converter fed induction motor drive using RB-IGBT," in *Conf. Rec. IEEE IAS Annu. Meeting*, 2005, vol. 4, pp. 2347–2354.
- [45] L. Empringham, P. Wheeler, and J. Clare, "Power density improvement and robust commutation for a 100 kW Si-SiC matrix converter," in *Proc. EPE*, 2009, pp. 1–8.
- [46] J. Galvez, X. Jorda, M. Vellvehi, J. Millan, M. Jose-Prieto, and J. Martin, "Intelligent bidirectional power switch module for matrix converter applications," in *Proc. Eur. Conf. Power Electron. Appl.*, 2007, pp. 1–9.
- [47] H. Fortin Blanchette and K. Al Haddad, "An efficient approach to design discrete packaging of bidirectional resonant power switch for matrix converter applications," *IEEE Trans. Power Electron.*, vol. 23, no. 4, pp. 2195–2200, Jul. 2008.
- [48] D. Chamund, B. Findlay, P. W. Wheeler, M. Apap, L. Empringham, M. Bland, and J. C. Clare, "Bi-directional IGBT switches for matrix converter applications," in *Proc. PCIM*, 2004, pp. 676–681.
- [49] M. Apap, "Direct Converter Technology Applied to an Integrated Motor Drive," Ph.D. dissertation, School of Elect. and Electron. Eng., Nottingham, U.K., 2005.
- [50] D. Casadei, G. Serra, A. Tani, and L. Zarri, "Effects of the switching strategy on the input power quality of matrix converters," in *Proc. IEEE Power Tech Conf.*, 2003, vol. 1, p. 8.
- [51] S. Bernet, S. Ponnaluri, and R. Teichmann, "Design and loss comparison of matrix converters, and voltage-source converters for modern ac drives," *IEEE Trans. Ind. Electron.*, vol. 49, no. 2, pp. 304–314, Apr. 2002.
- [52] P. Wheeler and D. Grant, "Optimized input filter design and low-loss switching techniques for a practical matrix converter," *Proc. IEE Elect. Power Appl.*, vol. 144, no. 1, pp. 53–60, Jan. 1997.
- [53] I. Galkin and A. Suzdalenko, "Analysis of the actual current paths of an integrated matrix converter," in *Proc. ICEMS*, 2009, pp. 1–5.
- [54] B. Kwon, B. Min, and J. Kim, "Novel commutation technique of ac-ac converters," *Proc. IEE Elect. Power Appl.*, vol. 145, no. 4, pp. 295–300, Jul. 1998.
- [55] A. Schuster, "A matrix converter without reactive clamp elements for an induction motor drive system," in *Proc. IEEE PESC/IEEE Power Electron. Spec. Conf.*, May 1998, vol. 1, pp. 714–720.
- [56] P. Nielsen, F. Blaabjerg, and J. Pedersen, "New protection issues of a matrix converter: Design considerations for adjustable-speed drives," *IEEE Trans. Ind. Appl.*, vol. 35, no. 5, pp. 1150–1161, Sep/Oct. 1999.
- [57] L. Empringham, L. de Lillo, P. Wheeler, and J. Clare, "Matrix converter protection for more electric aircraft applications," in *Proc. IEEE IECON*, 2006, pp. 2564–2568.
- [58] J. Schonberger, T. Friedli, S. Round, and J. Kolar, "An ultra sparse matrix converter with a novel active clamp circuit," in *Proc. PCC-Nagoya*, 2007, pp. 784–791.
- [59] J. Mahlein, M. Bruckmann, and M. Braun, "Passive protection strategy for a drive system with a matrix converter and an induction machine," *IEEE Trans. Ind. Electron.*, vol. 49, no. 2, pp. 297–303, Apr. 2002.
- [60] D. Zhou, K. Phillips, G. Skibinski, J. McCarty, M. Loth, B. Buchholz, D. Braun, and R. Lukaszewski, "Evaluation of ac-ac matrix converter, a manufacturer's perspective," in *Conf. Rec. IEEE IAS Annu. Meeting*, 2002, vol. 3, pp. 1558–1563.
- [61] T. Wijekoon, C. Klumpner, P. Zanchetta, and P. Wheeler, "Implementation of a hybrid ac-ac direct power converter with unity voltage transfer," *IEEE Trans. Power Electron.*, vol. 23, no. 4, pp. 1918–1926, Jul. 2008.

- [62] P. Wheeler, J. Clare, M. Apap, L. Empringham, L. De Lilo, K. Bradley, C. Whitley, and G. Towers, "An electro-hydrostatic aircraft actuator using a matrix converter permanent magnet motor drive," in *Proc. 2nd Int. Conf. (Conf. Publ. No. 498) PEMD*, 2004, vol. 2, pp. 464–468.
- [63] A. Trentin, P. Zanchetta, P. Wheeler, and J. Clare, "Performance assessment of matrix converter and two stage matrix converter for EMA in aircraft application," in *Proc. IEEE PESC/IEEE Power Electron. Spec. Conf.*, 2008, pp. 2692–2697.
- [64] T. Friedli and J. Kolar, "Comprehensive comparison of three-phase ac–ac matrix converter and voltage dc-link back-to-back converter systems," in *Proc. IPEC*, 2010, pp. 2789–2798.
- [65] P. Snary, B. Bhangu, C. Bingham, D. Stone, and N. Schofield, "Matrix converters for sensorless control of PMSMs and other auxiliaries on deep-sea ROVs," *Proc. IEE Elect. Power Appl.*, vol. 152, no. 2, pp. 382–392, Mar. 2005.
- [66] L. Zhang, C. Watthanasarn, and W. Shepherd, "Application of a matrix converter for the power control of a variable-speed wind-turbine driving a doubly-fed induction generator," in *Proc. IECON*, Nov. 1997, vol. 2, pp. 906–911.
- [67] R. Pena, R. Cardenas, E. Reyes, J. Clare, and P. Wheeler, "Control of a doubly fed induction generator via an indirect matrix converter with changing dc voltage," *IEEE Trans. Ind. Electron.*, vol. 58, no. 10, pp. 4664–4674, Oct. 2011.
- [68] R. Cardenas, R. Pena, G. Tobar, J. Clare, P. Wheeler, and G. Asher, "Stability analysis of a wind energy conversion system based on a doubly fed induction generator fed by a matrix converter," *IEEE Trans. Ind. Electron.*, vol. 56, no. 10, pp. 4194–4206, Oct. 2009.
- [69] K. Spiteri, C. Staines, and M. Apap, "Power control of doubly fed induction machine using a rotor side matrix converter," in *Proc. ISIE*, 2010, pp. 1445–1450.
- [70] A. Garces and M. Molinas, "Reduced matrix converter operated as current source for off-shore wind farms," in *Proc. EPE/PEMC*, 2010, pp. T12-149–T12-154.
- [71] A. Garces and M. Molinas, "A study of efficiency in a reduced matrix converter for offshore wind farms," *IEEE Trans. Ind. Electron.*, vol. 59, no. 1, pp. 184–193, Jan. 2012.
- [72] X. Liu, P. Wang, P. Loh, and F. Blaabjerg, "A three-phase dual-input matrix converter for grid integration of two ac type energy resources," *IEEE Trans. Ind. Electron.*, vol. 60, no. 1, pp. 20–30, Jan. 2013.
- [73] P. Zanchetta, P. Wheeler, J. Clare, M. Bland, L. Empringham, and D. Katsis, "Control design of a three-phase matrix-converter-based ac–ac mobile utility power supply," *IEEE Trans. Ind. Electron.*, vol. 55, no. 1, pp. 209–217, Jan. 2008.
- [74] S. Turri, A. Lacaze, and J. Kauffmann, "De-synchronized generator using a synchronous turbo-generator and a matrix converter," in *Proc. IEEE IEMDC*, 2003, vol. 1, pp. 60–66.
- [75] A. Beguin, A. Rufer, and A. Lacaze, "Poly-phased matrix converter for large synchronous generators—Design of the voltage surge protection," in *Proc. EPE*, 2009, pp. 1–10.
- [76] B. Augdahl, H. Hess, and B. Johnson, "Output protection strategies for matrix converters in distributed generation applications," in *Conf. Rec. IEEE IAS Annu. Meeting*, 2006, vol. 4, pp. 2082–2089.
- [77] H. Nikkhajoei and M. Iravani, "A matrix converter based micro-turbine distributed generation system," *IEEE Trans. Power Del.*, vol. 20, no. 3, pp. 2182–2192, Jul. 2005.
- [78] M. Ziegler, D. Domes, W. Hofmann, and S. El-Barbari, "A new rectifier based topology for electrical drives: S-A-X-converter," in *Proc. IEEE PESC/IEEE Power Electron. Spec. Conf.*, 2004, vol. 4, pp. 2924–2928.
- [79] C. Gerada, K. Bradley, X. Huang, A. Goodman, C. Whitley, and G. Towers, "A 5-phase fault-tolerant brushless permanent magnet motor drive for an aircraft thin wing surface actuator," in *Proc. IEEE IEMDC*, May 2007, vol. 2, pp. 1643–1648.
- [80] A. Goodman, K. Bradley, and P. Wheeler, "Evaluation of the single sided matrix converter driven switched reluctance motor," in *Conf. Rec. IEEE IAS Annu. Meeting*, 2004, vol. 3, pp. 1847–1851.
- [81] I. Sato, A. Odaka, Y. Tamai, and H. Mine, "Technologies for practical motor drive system with matrix converter," Fuji Electric Advanced Technology, Ltd, Tokyo, Japan, 2007.
- [82] F. Schafmeister, S. Herold, and J. Kolar, "Evaluation of 1200 V-Si-IGBTs and 1300 V-SiC-JFETs for application in three-phase very sparse matrix ac–ac converter systems," in *Proc. IEEE APEC*, 2003, vol. 1, pp. 241–255.
- [83] M. Heldwein and J. Kolar, "A novel SiC J-FET gate drive circuit for sparse matrix converter applications," in *Proc. IEEE APEC*, 2004, vol. 1, pp. 116–121.



**Lee Empringham** (M'10) received the B.Eng. (Hons.) degree in electrical and electronic engineering and the Ph.D. degree from The University of Nottingham, Nottingham, U.K., in 1996, and 2000, respectively.

He then joined the Power Electronics, Machines and Control Group within the School of Electrical and Electronic Engineering, The University of Nottingham to work on matrix converter commutation techniques. Since then, he has been employed by the group as a research fellow to support different ongoing matrix converter projects and has recently been appointed to the position of Principal Research Fellow. His research interests include direct ac–ac power conversion, variable-speed ac motor drives using different circuit topologies, and more electric/electric aircraft applications.

Dr. Lee Empringham is a member of the Institution of Electrical Engineers.



**Johann W. Kolar** (M'89–SM'04–F'10) received the Ph.D. degree (*summa cum laude/promotio sub auspiciis praesidentis rei publicae*) from the University of Technology Vienna, Vienna, Austria.

Since 1984, he has been working as an Independent International Consultant in close collaboration with the University of Technology Vienna, in the fields of power electronics, industrial electronics, and high-performance drives. He has proposed numerous novel PWM converter topologies and modulation and control concepts, e.g., the VIENNA rectifier and the three-phase ac–ac sparse matrix converter. He has published more than 300 scientific papers in international journals and conference proceedings and has filed more than 75 patents. He joined the Power Electronic Systems Laboratory, Swiss Federal Institute of Technology (ETH) Zurich, Zurich, Switzerland, on February 1, 2001. His current research interests include ac–ac and ac–dc converter topologies with low effects on the mains, e.g., for power supply of telecommunication systems, more electric aircraft, and distributed power systems in connection with fuel cells. Further main areas are the realization of ultracompact intelligent converter modules employing the latest power semiconductor technology (SiC), novel concepts for cooling and EMI filtering, multidomain/multiscale modeling and simulation, pulsed power, and bearingless motors.

Dr. Kolar was the recipient of the Best Transactions Paper Award of the IEEE Industrial Electronics Society in 2005. He is a member of the Institute of Electrical Engineers of Japan (IEEJ) and of technical program committees of numerous international conferences in the field (e.g., Director of the Power Quality Branch of the International Conference on Power Conversion and Intelligent Motion). From 1997 to 2000, he was an Associate Editor of the IEEE TRANSACTIONS ON INDUSTRIAL ELECTRONICS, and since 2001, he has been an Associate Editor of the IEEE TRANSACTIONS ON POWER ELECTRONICS. Since 2002, he has also been an Associate Editor of the *Journal of Power Electronics* of the Korean Institute of Power Electronics and a member of the Editorial Advisory Board of the IEEJ *Transactions on Electrical and Electronic Engineering*.



**Jose Rodriguez** (M'81–SM'94–F'10) received the Engineer degree in electrical engineering from the Universidad Tecnica Federico Santa Maria (UTFSM), Valparaiso, Chile, in 1977, and the Dr. Ing. degree in electrical engineering from the University of Erlangen, Erlangen, Germany, in 1985.

He has been with the Department of Electronics Engineering, UTFSM, since 1977, where he is currently a Full Professor and Rector. He has coauthored more than 300 journal and conference papers. His main research interests include multilevel inverters,

new converter topologies, control of power converters, and adjustable-speed drives.

Prof. Rodríguez is a member of the Chilean Academy of Engineering. He has been an Associate Editor of the IEEE TRANSACTIONS ON POWER ELECTRONICS and the IEEE TRANSACTIONS ON INDUSTRIAL ELECTRONICS since 2002. He was the recipient of the Best Paper Award from the IEEE TRANSACTIONS ON INDUSTRIAL ELECTRONICS in 2007 and the Best Paper Award from the IEEE INDUSTRIAL ELECTRONICS MAGAZINE in 2008.



**Pat W. Wheeler** (M'00) received the B.Eng. (Hons.) and the Ph.D. degrees in electrical engineering for his work on matrix converters from the University of Bristol, Bristol, U.K., in 1990 and 1994, respectively.

In 1993, he moved to The University of Nottingham, Nottingham, U.K., and worked as a Research Assistant in the Department of Electrical and Electronic Engineering. In 1996, he became a Lecturer in the Power Electronics, Machines and Control Group at The University of Nottingham.

Since January 2008, he has been a Full Professor in the same research group. He has published over 200 papers in leading international conferences and journals. His research interests are in power conversion and more electric aircraft technology.



**Jon C. Clare** (M'90–SM'04) was born in Bristol, U.K. He received the B.Sc. and Ph.D. degrees in electrical engineering from the University of Bristol, Bristol.

Since 1990, he has been with The University of Nottingham, Nottingham, U.K., where he is currently a Professor of Power Electronics and the Head of the Power Electronics, Machines and Control Research Group. His research interests are in power electronic systems and applications, power electronic converter topologies, and their control. His

work is currently directed toward applications in aerospace, energy systems, and high-power RF.

Prof. Clare is a member of the Institution of Engineering and Technology (IET) England. He is a member of the Editorial Board of the IET Journal of Power Electronics and is an Associate Editor for the IEEE TRANSACTIONS ON POWER ELECTRONICS. He is a former member of the Executive Council of the European Power Electronics Association and the IEEE Power Electronics Society Administrative Committee.