



Power Electronic Systems
Laboratory

© 2013 IEEE

Proceedings of the IEEE Energy Conversion Congress and Exposition (ECCE USA 2013), Denver, Colorado, USA,
September 15-19, 2013

Phase-Oriented Control of a Modular 3-Phase 3-Level 4-Leg Inverter AC Power Source Supplying Floating or Grounded Loads

P. Cortés,
D. O. Boillat,
J. W. Kolar

This material is published in order to provide access to research results of the Power Electronic Systems Laboratory / D-ITET / ETH Zurich. Internal or personal use of this material is permitted. However, permission to reprint/republish this material for advertising or promotional purposes or for creating new collective works for resale or redistribution must be obtained from the copyright holder. By choosing to view this document, you agree to all provisions of the copyright laws protecting it.



Eidgenössische Technische Hochschule Zürich
Swiss Federal Institute of Technology Zurich

Phase-Oriented Control of a Modular 3-Phase 3-Level 4-Leg Inverter AC Power Source Supplying Floating or Grounded Loads

Patricio Cortes, David O. Boillat, Johann W. Kolar
Power Electronic Systems Laboratory, ETH Zurich, Switzerland
cortes@lem.ee.ethz.ch

Abstract—A control scheme for a high-performance three-phase AC power source is presented. The four-leg inverter output stage uses three bridge legs to generate the phase output voltages with reference to the neutral point potential, which is defined by the fourth bridge leg. The inverter is controlled using a phase-oriented control in order to achieve precise control of each output phase with unbalanced voltages and any kind of load. The neutral potential is controlled for maximum modulation range in case of floating load and controlled to zero for grounded load. The control scheme for the input PWM rectifier stage considers the control of the zero sequence voltage in order to prevent the appearance of circulating currents through the ground loop when the load star point is connected to ground. The control of the circulating currents also allows the safe parallel connection of two or more AC sources.

Simulation results under balanced and unbalanced conditions demonstrate the performance of the AC source in terms of output voltage control and prevention of circulating ground currents.

I. INTRODUCTION

High-performance AC power sources are a very important tool for testing new power electronics converters supplied from single-phase or three-phase AC mains. They allow to verify the behavior of the new equipment under different operating conditions such as the presence of harmonics in the supply voltage, and grid failures like loss of a phase of a three-phase supply [1]–[3]. Accordingly, an important requirement for the AC source is the generation of balanced or unbalanced voltages, even DC, as well as operation with unbalanced or nonlinear loads, including single-phase loads. In case of loads with a ground connection, the AC source must ensure that no current is circulating through the ground loop occurring through the ground connection of the mains star point. It is also highly desirable to allow the parallel connection of two or more AC sources, using them as modules in order to increase the power rating of the system. Any currents circulating between the modules must be avoided.

In order to handle unbalanced or nonlinear loads, a fourth leg is included in the output stage providing a neutral point connection. In addition, the use of a fourth leg allows to increase the output voltage range and to reduce the DC-link capacitors, in comparison to the direct connection of the neutral point of the load to the midpoint of the DC-link [4]. Modeling and control of 4-leg systems have been studied in the literature and several modulation and control

schemes have been proposed. Most of the control schemes consider a coordinates transformation using a static or rotating reference frame and an equivalent circuit, representing the 4-leg system as three single-phase systems [4]–[7]. The use of carrier-based pulse width modulation (PWM) [8], as well as space vector modulation (SVM) using a three-dimensional representation of the voltage vectors have been proposed in the literature [4], [9], [10]. All these approaches consider three-phase sinusoidal voltages and are not suitable or easily applicable if the reference voltages can have any programmed waveform, including DC.

Considering the AC source as a module, three types of circulating currents can be identified: zero sequence currents, module ground currents and, for parallel connected modules, inter module circulating currents. Zero sequence currents circulate inside the power converter and can be controlled in order to provide some additional advantage in the operation of the converter, e.g. maximize the output modulation range of the inverter. Module ground currents can appear when supplying voltage to loads with connection to ground, as the star point of the mains supplying the AC source is tied to ground. This effect is more likely to appear with unbalanced loads, nonlinear loads and active loads. Accordingly, the design of the AC source circuit and control scheme must consider the mitigation of the module ground currents, providing safe operation with ground connected loads. The inclusion of an isolation stage could prevent the appearance of circulating currents but it requires a higher implementation effort. Inter module currents circulate between parallel connected AC source modules, and can generate uneven power distribution between the modules and distortion of the input currents. This problem has been discussed in the literature considering the parallel connection of voltage source rectifiers [11]–[13], current source rectifiers [14] and voltage source inverters [15], [16]. The control scheme of each AC source module must consider the regulation of the zero-sequence currents at the input side in order to have a balanced operation of the modules without inter module currents. At the output side, a master-slave configuration of the modules can be implemented in order to guarantee equal sharing of the load current.

In this paper, the four-leg inverter uses a phase-oriented control scheme, allowing independent operation of each phase of the power source with any type of voltage references

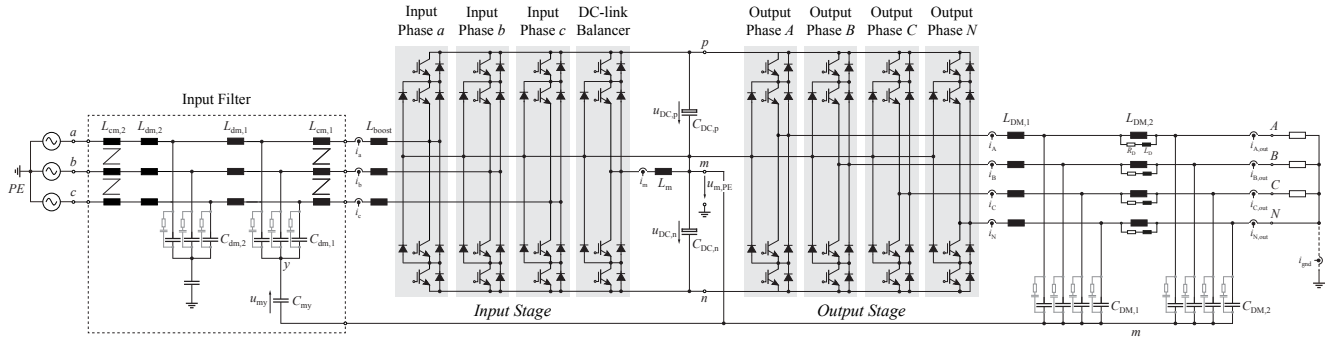

Fig. 1: Input and output stages of the AC source.

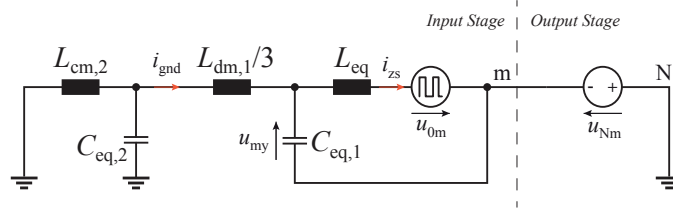

Fig. 2: Modelling of the ground current equivalent circuit for a grounded load.

and any type of load. The neutral potential is controlled for maximum modulation range in case of floating load and controlled to zero for grounded load. The control scheme of the input PWM rectifier considers the control of the zero sequence voltages in order to prevent the appearance module ground current and inter module currents, allowing the operation with ground connected loads and the parallel connection of several AC power source modules.

II. PROPOSED CONTROL SCHEME

A. Control Scheme for the AC Source (One module)

The power circuit of the AC source considered in this work is shown in **Fig. 1**. The power converter is based on the three-level neutral point clamped (NPC) topology. At the input side, a three-phase voltage source rectifier provides controlled DC-link voltages and sinusoidal input currents. An input filter is included and it is assumed that the neutral point of the grid is connected to ground. The star point of the filter capacitors y is connected to the midpoint of the DC-link m through another capacitor C_{my} , allowing the control of the midpoint potential with respect to ground. In order to ensure the proper balance of the DC-link capacitor voltages under any operating conditions, a balancer circuit is included in the input stage of the converter. The output side has four legs with two-stage LC filters providing controlled output voltages at the phase terminals A , B , C and at the neutral terminal N . The output voltages of phases A , B and C are defined with respect to the neutral terminal N . A fully symmetrical output filter is selected for the output stage, with identical two-stage LC filters for the four output phases. This filter structure allows decoupled control of each phase voltage. The

reference value for the neutral phase voltage u_{Nm} can be selected in order to maximize the output voltage range of the three output phases or to be zero in case of loads connected to ground. The load can be balanced or unbalanced, linear or nonlinear, and with or without connection to ground.

In order to design a controller for the ground current, the model shown in **Fig. 2** is considered. The input side of the AC source is modeled in terms of the zero sequence components of the converter voltages and currents, and the common mode equivalent circuit of the input filter. The output stage considers only the elements that affect the behavior of the ground current, i.e. the voltage at the neutral point N , with respect to the midpoint m of the dc-link, and the ground connection of the load. When a grounded load is connected at the output terminals, the neutral point output voltage u_{Nm} defines the potential of the midpoint m with respect to ground. For this reason the reference output voltage u_{Nm}^* must be set to zero for operation with grounded load.

As it can be observed in **Fig. 2**, the ground current can be controlled by means of the voltage u_{my} (the output voltage u_{Nm} can be considered a disturbance in the control loop), which can be modified by the zero sequence current component i_{zs} . This idea leads to a cascaded control structure as shown in **Fig. 3**. A PI controller regulates the ground current i_{gnd} with a reference value equal to zero. The output of this controller and a feedforward loop of the output neutral voltage u_{Nm} generate the reference voltage u_{my}^* . The second PI controller regulates the capacitor voltage u_{my} and its output is the reference value for the zero sequence current controller. This third controller provides a fast control of the zero sequence current i_{zs} and generates the reference for the

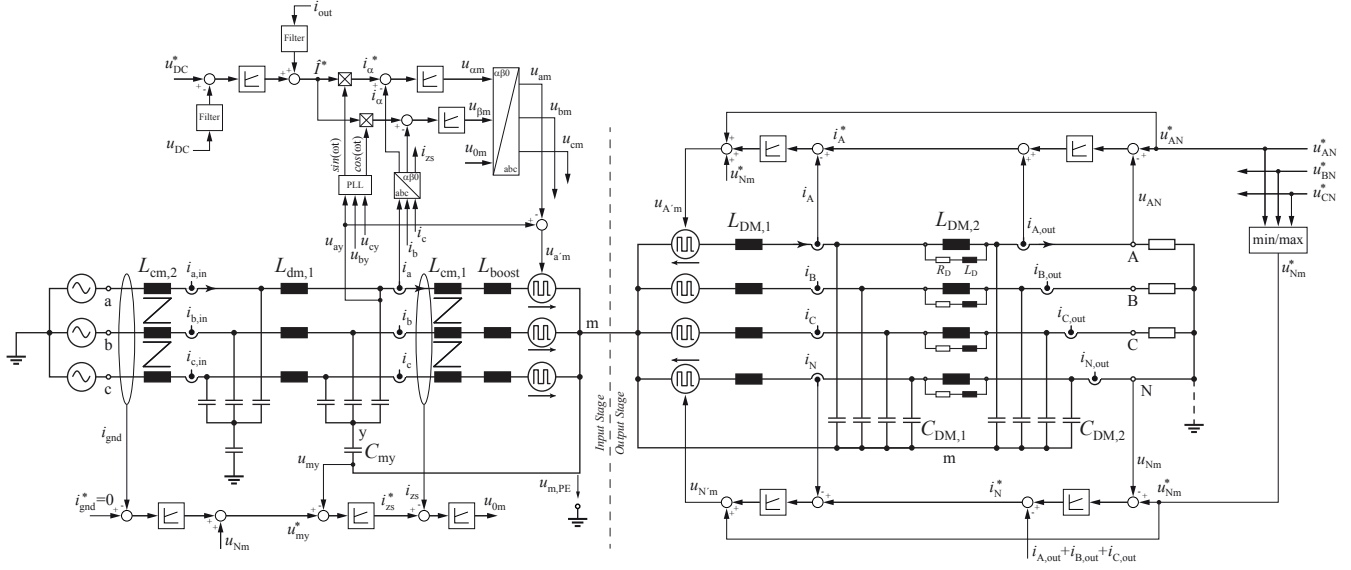

Fig. 3: Diagram of the control scheme of the input and output stages.

zero sequence voltage u_{0m} .

In the input stage, a PI controller regulates the total DC-link voltage u_{DC} and generates the reference for the input phase current amplitude \hat{I}^* , including a feedforward loop of the output current i_{out} , which can be obtained from the output stage controller variables:

$$i_{out} = \frac{u_{AN}^* i_{A,out} + u_{BN}^* i_{B,out} + u_{CN}^* i_{C,out}}{u_{DC}}. \quad (1)$$

A moving average filter is used for the dc-link voltage u_{DC} and load current i_{out} in order to avoid distortions in the input currents due to periodic variations of the dc-link voltage generated by unbalanced operation of the output stage, e.g. with a single phase load.

The input currents are controlled in the $\alpha\beta 0$ reference frame. The reference current for each component is calculated using the input voltage waveforms and the current magnitude \hat{I}^* . A phase-locked loop (PLL) extract the input voltage angle from the capacitor voltages measurements, which is required for the generation of the α and β components of the current references. Then, the reference voltages $u_{\alpha m}$, $u_{\beta m}$ and u_{0m} are transformed to the abc reference frame and a feedforward loop of the input filter capacitor voltages is included.

At the output stage, the voltage references can have any programmed waveform, including three-phase voltages, single-phase with different frequencies and DC voltages. Considering these kind of references, a space vector representation is not suitable, and the use of a rotating reference frame or resonant controllers does not allow the required flexibility required to handle different single-phase references. Consequently, a phase-oriented control is proposed for the output stage. Each phase is controlled independently using a cascaded structure

with an inner current control loop and an outer voltage control loop, including feedforward loops of the load phase currents and reference voltages. The selection of the control scheme for high-bandwidth AC sources is discussed in detail in [17]. By using a high-bandwidth controller, the steady state error for sinusoidal references is negligible.

The reference for the neutral phase voltage u_{Nm} is calculated in order to maximize the voltage range of the other three output phases:

$$u_{Nm}^* = -\frac{\min(u_{AN}^*, u_{BN}^*, u_{CN}^*) + \max(u_{AN}^*, u_{BN}^*, u_{CN}^*)}{2}. \quad (2)$$

In case of ground connection of phase N , the reference voltage is set to zero, i.e. $u_{Nm}^* = 0$.

B. Control Scheme for Parallel Connection of AC Sources

When two or more AC sources are connected in parallel, the control scheme of each AC source remains the same at the input side, but a master-slave scheme is considered for the output stages. This means, only one AC source performs the control of the output voltages (master) and provides the current references for the other AC sources (slaves). A diagram of the connection of two AC sources is shown in **Fig. 4**. Here, the output voltage and current references are transferred from the master module to the slave module.

III. SIMULATION RESULTS

Simulations of the AC power source circuit shown in **Fig. 1** with the control scheme shown in **Fig. 3** are setup using GeckoCIRCUITS [18].

The behavior of the output stage of the AC source is shown in **Fig. 5** for balanced three-phase output voltages

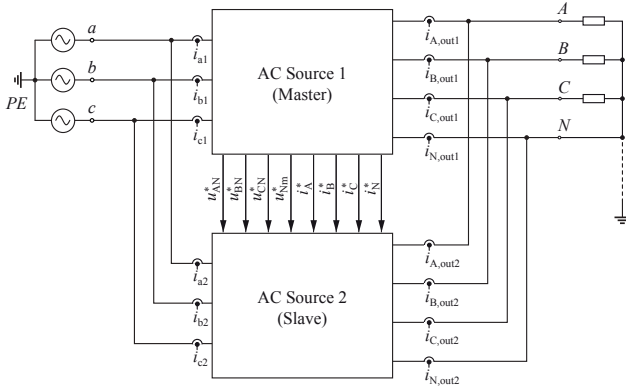

Fig. 4: Parallel connection of two AC sources.

and a floating three-phase load. Results for a balanced load are shown in **Fig. 5(a)**. The output phase voltages (measured with respect to the neutral phase N) are sinusoidal while the output voltages with respect to the DC-link midpoint m are optimized to maximize the output voltage range. The neutral phase voltage u_{Nm} reference value is calculated according to (2). The current in the neutral phase i_N is equal to zero. An unbalanced load, with a 200% higher resistance in phase C , has been used for the results shown in **Fig. 5(b)**. The current in the neutral phase i_N is different than zero allowing the operation of the AC source with unbalanced three-phase currents.

The operation of the AC source with balanced three-phase voltages and a nonlinear load is shown in **Fig. 6(a)**. A three-phase diode bridge rectifier is used as a load. The neutral terminal N is not connected. Three independent single-phase sources are considered in the results shown in **Fig. 6(b)**. Each phase has a different reference, phase A with a 50Hz sinusoidal reference, phase B with a 100Hz sinusoidal reference and phase C as a DC source. The star point of the three-phase load is connected to N . The neutral phase voltage u_{Nm} , as well as the phase voltages with respect to the midpoint of the DC-link are optimized for maximization of the output voltage range.

The operation of the AC source with a ground connected load is shown in **Fig. 7** for an unbalanced load. Balanced three-phase references are set for the output voltages and the neutral phase voltage u_{Nm}^* is set to zero. In order to assess the effectiveness of the proposed scheme, results for an input control scheme without ground current control are shown in **Fig. 7(a)**. In this scheme, the zero sequence current i_{zs} is controlled with a reference $i_{zs}^* = 0$. It can be observed that due to the small variations in the output neutral point voltage u_{Nm} , a current with a magnitude of 12 mA circulates in the ground loop. When the ground current is controlled using the scheme shown in **Fig. 3**, the ground current i_{gnd} can be reduced to less than 1 mA, as shown in **Fig. 7(b)**.

The parallel connection of two AC sources is simulated using a master-slave configuration for the output stage control (cf. **Fig. 4**). Results for a step change in the magnitude of

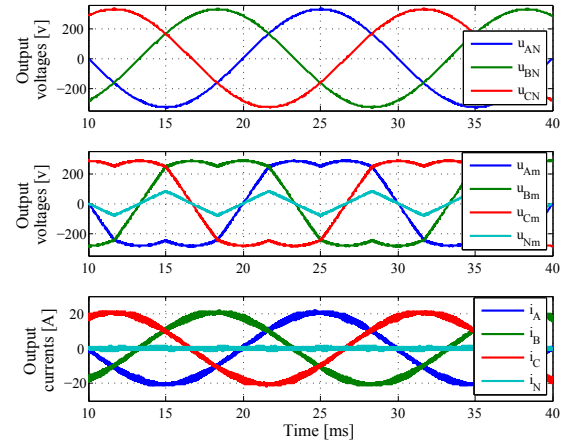

(a) Balanced load

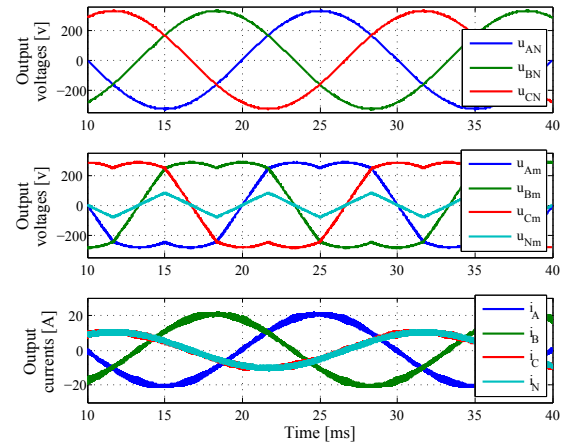

(b) Unbalanced load

Fig. 5: Simulation results for the AC source operating with balanced three-phase voltages. The star point of the three-phase load is connected to N . The unbalanced load presents a 200% higher resistance in phase C .

the three-phase reference voltages are shown in **Fig. 8**. An unbalanced and grounded three-phase load is used for these results. It can be observed in **Fig. 8(a)** that the magnitude of the input currents change due to the step change in the output stage and equal charging of the input currents is achieved. The ground current i_{gnd} is kept near zero, except during the transient where this current presents a peak value of 15 mA during a very short period of time. At the output stage, the output voltages present a fast transient with negligible overshoot. The neutral phase voltage u_{Nm} presents a deviation of 3 V during the transient.

Results for a step change in the load resistance is shown in **Fig. 9**. The power of a balanced three-phase load is changed from 10 kW to 20 kW. The input currents are well distributed between the two converters and a small peak in the ground

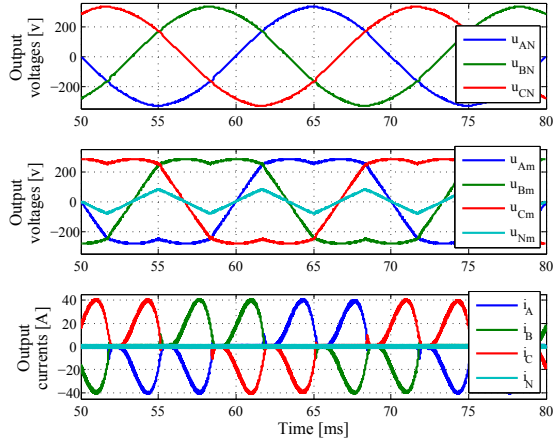

(a) Nonlinear load

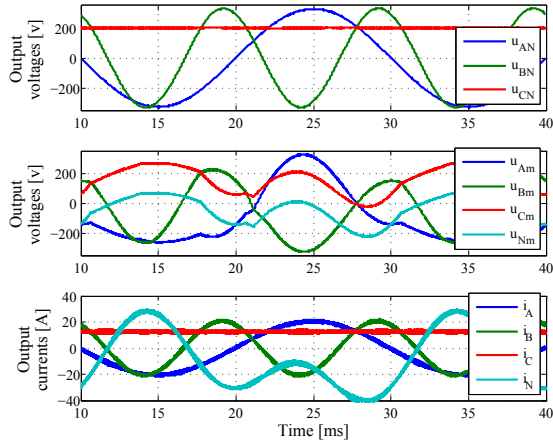

(b) Unbalanced voltages

Fig. 6: Simulation results for the AC source operating with nonlinear load and with unbalanced voltages. (a) A diode bridge rectifier is used as a nonlinear load. (b) Each phase works as an independent source: phase *A* with a 50Hz sinusoidal reference, phase *B* with a 100Hz sinusoidal reference and phase *C* as a DC source. The star point of the three-phase load is connected to *N*.

currents present during the transient, as shown in **Fig. 9(a)**. The good regulation of the output voltages is observed and a 1V deviation in the neutral phase voltage u_{Nm} is present during the transient, as shown in **Fig. 9(b)**. Equal sharing of the output currents is achieved with the master-slave scheme.

IV. CONCLUSIONS

A control scheme for a high-performance AC source is presented. The additional degree of freedom introduced by the supplementary bridge-leg for the neutral phase can be utilized to maximize the 3-phase output voltages for floating loads; or it can be used to control the neutral point potential to zero for grounded loads. A phase-oriented control scheme

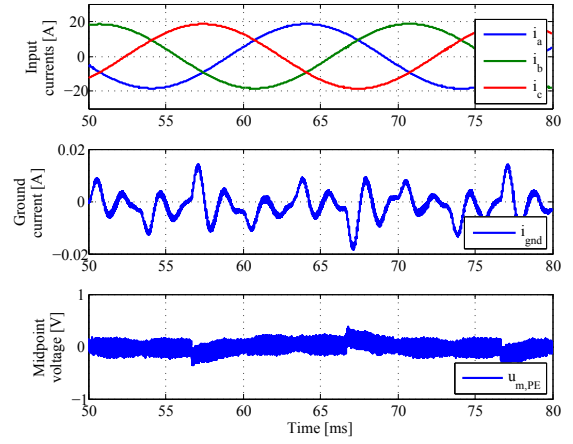

(a) Without module ground current control

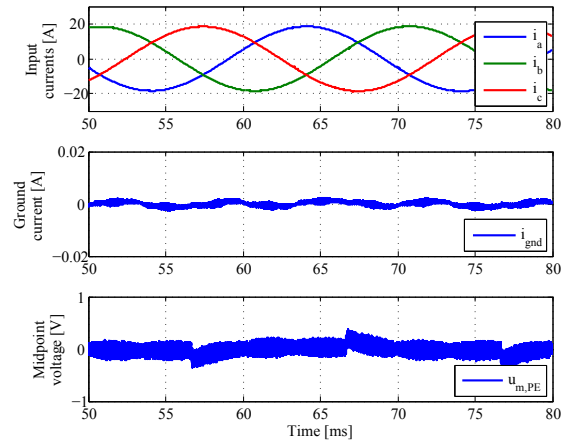

(b) With module ground current control

Fig. 7: Simulation results for the AC source operating with balanced three-phase output voltages and unbalanced load. The unbalanced load presents a 200% higher resistance in phase *C*.

allows independent control of each output phase voltage and the operation with any kind of reference. A high-bandwidth controller is required for negligible steady state errors with sinusoidal references.

The control of the input stage uses the zero sequence voltage for controlling the ground current between the mains star point and the load neutral point in case of grounded loads. The proposed cascaded control scheme takes into account the multi-stage structure of the input filter and the influence of the output stage to effectively reduce the ground current. This control also prevents the circulation of currents between the modules in case of parallel operation of several AC sources. Simulation results under different operating conditions verify the proposed control scheme. Further verification will be performed with measurements on a 10kW laboratory prototype.

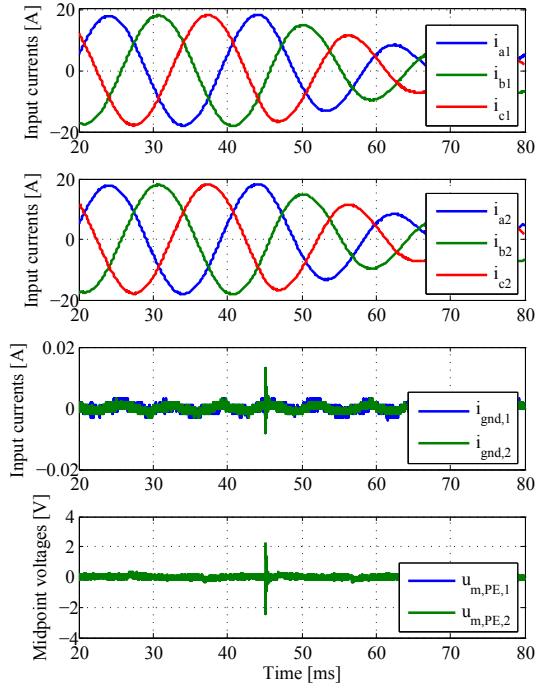

(a) Input currents.

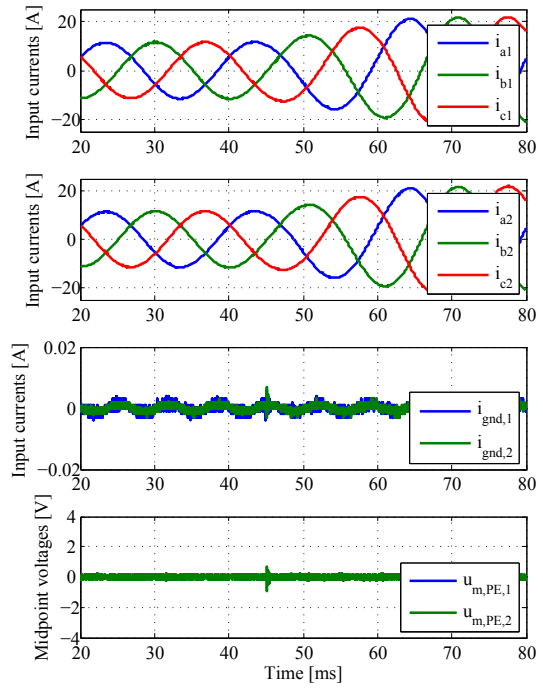

(a) Input currents.

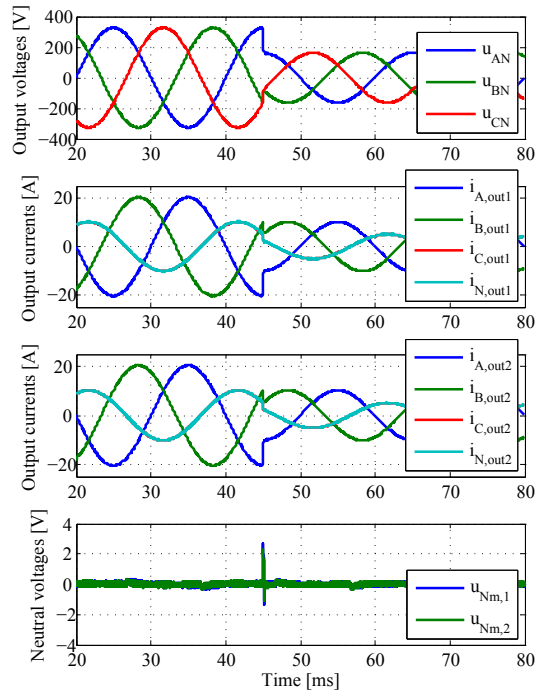

(b) Output voltages and currents.

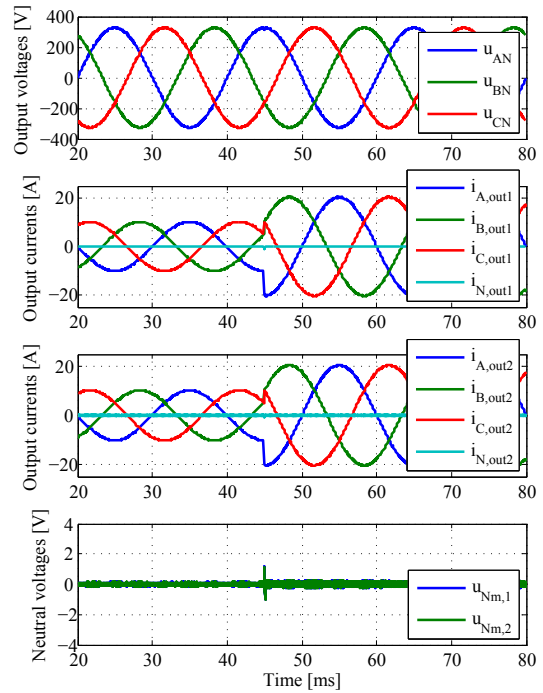

(b) Output voltages and currents.

Fig. 8: Results for a step change in amplitude of the reference voltages for parallel connection of two AC sources feeding a grounded unbalanced load (phase C presents a 200% higher resistance). A master-slave scheme is used for the output stage control.

Fig. 9: Results for a step change in the load resistance for parallel connection of two AC sources feeding a grounded balanced load (the load power is increased from 10 kW to 20 kW). A master-slave scheme is used for the output stage control.

REFERENCES

- [1] N. Kim, S.-Y. Kim, H.-G. Lee, C. Hwang, G.-H. Kim, H.-R. Seo, M. Park, and I.-K. Yu, "Design of a grid-simulator for a transient analysis of grid-connected renewable energy system," in *International Conference on Electrical Machines and Systems (ICEMS)*, Oct. 2010, pp. 633 – 637.
- [2] R. Lohde and F. Fuchs, "Laboratory type PWM grid emulator for generating disturbed voltages for testing grid connected devices," in *13th European Conference on Power Electronics and Applications (EPE '09)*, Sept. 2009, pp. 1 – 9.
- [3] O. Craciun, A. Florescu, S. Bacha, I. Munteanu, and A. Bratcu, "Hardware-in-the-loop testing of PV control systems using RT-Lab simulator," in *14th International Power Electronics and Motion Control Conference (EPE/PEMC)*, Sept. 2010, pp. S2-1 –S2-6.
- [4] R. Zhang, D. Boroyevich, V. Prasad, H.-C. Mao, F. Lee, and S. Dubovsky, "A three-phase inverter with a neutral leg with space vector modulation," in *Proceedings of the 12th Applied Power Electronics Conference and Exposition (APEC'97)*, vol. 2, Feb. 1997, pp. 857 – 863.
- [5] S. El-Barbari and W. Hofmann, "Control of a 4 leg inverter for standalone photovoltaic systems," in *Proceedings of the 4th IEEE International Conference on Power Electronics and Drive Systems*, vol. 1, Oct. 2001, pp. 348 – 354.
- [6] M. Ryan, R. De Doncker, and R. Lorenz, "Decoupled control of a four-leg inverter via a new 4x4 transformation matrix," *IEEE Transactions on Power Electronics*, vol. 16, no. 5, pp. 694 – 701, Sept. 2001.
- [7] M. Ryan, "Analysis, modeling and control of three-phase, four-wire sine wave inverter systems," Ph.D. dissertation, University of Wisconsin - Madison, 1997.
- [8] J.-H. Kim and S.-K. Sul, "A carrier-based PWM method for three-phase four-leg voltage source converters," *IEEE Transactions on Power Electronics*, vol. 19, no. 1, pp. 66 – 75, Jan. 2004.
- [9] J. Ai-juan, L. Hang-tian, and L. Shao-long, "A new matrix type three-phase four-wire power electronic transformer," in *Proceedings of the 37th IEEE Power Electronics Specialists Conference (PESC '06)*, June 2006, pp. 1 – 6.
- [10] R. Zhang, V. Prasad, D. Boroyevich, and F. Lee, "Three-dimensional space vector modulation for four-leg voltage-source converters," *IEEE Transactions on Power Electronics*, vol. 17, no. 3, pp. 314 – 326, May 2002.
- [11] Z. Ye, D. Boroyevich, J.-Y. Choi, and F. Lee, "Control of circulating current in two parallel three-phase boost rectifiers," *IEEE Transactions on Power Electronics*, vol. 17, no. 5, pp. 609 – 615, Sept. 2002.
- [12] C.-T. Pan and Y.-H. Liao, "Modeling and coordinate control of circulating currents in parallel three-phase boost rectifiers," *IEEE Transactions on Industrial Electronics*, vol. 54, no. 2, pp. 825 – 838, April 2007.
- [13] —, "Modeling and control of circulating currents for parallel three-phase boost rectifiers with different load sharing," *IEEE Transactions on Industrial Electronics*, vol. 55, no. 7, pp. 2776 – 2785, July 2008.
- [14] M. Baumann and J. Kolar, "Parallel connection of two three-phase three-switch buck-type unity-power-factor rectifier systems with dc-link current balancing," *IEEE Transactions on Industrial Electronics*, vol. 54, no. 6, pp. 3042 – 3053, Dec. 2007.
- [15] H. Shan, Y. Zhang, M. Yu, Y. Kang, Y. Liu, M. Yin, and H. Li, "The novel strategy of restraining circulating currents in distributed-logical-control on parallel inverter system," in *Proceedings of the International Conference on Electrical Machines and Systems (ICEMS 2009)*, Nov. 2009, pp. 1 – 5.
- [16] S. Ji, Y. Yong, and Q. Chunqing, "Control of circulating current for direct parallel grid-connected inverters in photovoltaic power generation," in *Proceedings of the International Conference on Mechatronics and Automation (ICMA 2009)*, Aug. 2009, pp. 3805 – 3810.
- [17] P. Cortes, D. Boillat, H. Ertl, and J. Kolar, "Comparative evaluation of multi-loop control schemes for a high-bandwidth AC power source with a two-stage LC output filter," in *International Conference on Renewable Energy Research and Applications (ICRERA 2012)*, 2012, pp. 1–10.
- [18] Gecko-Simulations. [Online]. Available: <http://www.gecko-simulations.com>