



Power Electronic Systems
Laboratory

© 2011 IEEE

Proceedings of the 37th Annual Conference of the IEEE Industrial Electronics Society (IECON 2011), Melbourne, Australia, November 7-10, 2011.

New Unidirectional Hybrid Delta-Switch Rectifier

T. Soeiro
T. Friedli
M. Hartmann
J. W. Kolar

This material is posted here with permission of the IEEE. Such permission of the IEEE does not in any way imply IEEE endorsement of any of ETH Zurich's products or services. Internal or personal use of this material is permitted. However, permission to reprint/republish this material for advertising or promotional purposes or for creating new collective works for resale or redistribution must be obtained from the IEEE by writing to pubs-permissions@ieee.org. By choosing to view this document, you agree to all provisions of the copyright laws protecting it.



Eidgenössische Technische Hochschule Zürich
Swiss Federal Institute of Technology Zurich

New Unidirectional Hybrid Delta-Switch Rectifier

Thiago B. Soeiro, Thomas Friedli, Michael Hartmann and Johann W. Kolar
 Power Electronic Systems Laboratory, ETH Zürich, Physikstrasse 3, CH-8092 Zürich, Switzerland.
 E-mail: soeiro@lem.ee.ethz.ch

Abstract— This paper introduces a novel 3-phase hybrid rectifier assembled by the parallel connection of a 3-phase diode bridge boost rectifier with a 2-level unidirectional delta-switch rectifier. This system aims to take advantage of the commonly low power losses and high reliability of a diode based rectifier and also to benefit from the delta-rectifier capability of processing reactive power. Therefore, a highly efficient and reliable high power factor rectifier system with controlled dc-link voltage is constructed. Additionally, this work presents an efficiency comparison between the proposed hybrid delta-switch rectifier and other concepts such as the new 3-level unidirectional hybrid T-type or VIENNA 6-switch rectifiers and the single self-commutated converters, including the VIENNA 6-switch, delta-switch and T-type rectifiers for 10 kW 50 Hz operation. It is shown that the hybrid systems can achieve higher efficiency than the single self-commutated rectifier they are based on. Finally, experimental results obtained with an assembled unidirectional hybrid delta-switch rectifier prototype are presented in order to demonstrate the performance and feasibility of this solution.

I. INTRODUCTION

In general, 3-phase ac-to-dc power converters can be classified into line- and self-commutated rectifiers [1]. The first, also known as passive rectifiers employ diode and/or thyristor based switches, which commute at the zero crossing of the ac side currents. The former concept, also known as active rectifiers, uses semiconductor technologies, such as, IGBTs, MOSFETs, GTOs, IGCTs, and so forth, which are cable of actively controlling the ac side currents.

Passive rectifiers are commonly inexpensive, very reliable and highly efficient. On the other hand, they usually inject significant current harmonics into the power grid and additional filtering concepts would be necessary to attain unity power factor operation. Consequently, simple rectifiers do not meet IEC 61000-3-2/61000-3-4 guidelines [1].

From the power quality point of view, the active rectifiers

are the most promising concept as they can operate at low current THD and high power factor. Nevertheless, they are more expensive, less reliable and display lower efficiency than passive rectifiers [2].

In medium and high power applications the pursuit for unity power factor rectifier topologies, which combine robustness, simplicity, low cost, and high power density with light weight, has lead the research in this area to a new class of ac-to-dc converters, the hybrid rectifiers [1]-[4]. The term “hybrid rectifier” denotes the parallel connection of a line- and a self-commutated converter [5]. Fig. 1 presents four hybrid rectifiers suitable for shaping the line currents, and also to control the DC-link voltage, U_{DC} . The unipolar and bidirectional switches shown in Fig 1 can be implemented with many basic switch types shown in Fig. 2.

Hybrid rectifiers aim to embrace the best features of a passive rectifier and the advantages of active rectifiers. In general, the line-commutated based converter is set to operate with low frequency, processing the highest power rating, while the active system is adjusted to work at higher frequencies and lower power rating [1]. Therefore, a highly efficient rectifier system, capable of providing close to sinusoidal shaped line current can be assembled. When compared to rectifier systems based simply on connection of active rectifiers, the hybrid systems are usually cheaper, more robust and more efficient [5].

In this work the hybrid rectifier concept is distinguished from an ordinary parallel association of rectifiers. For instance, in an ac-to-dc system assembled by a parallel connection of two unity power factor rectifiers, the input current in each unit is ideally sinusoidal. Additionally, each rectifier part is normally set to operate at the same switching frequency and to equally share the total load power. On the other hand, the rectifier units of the hybrid arrangements can operate with different power ratings at different frequencies. In these systems the line currents with sinusoidal shape are

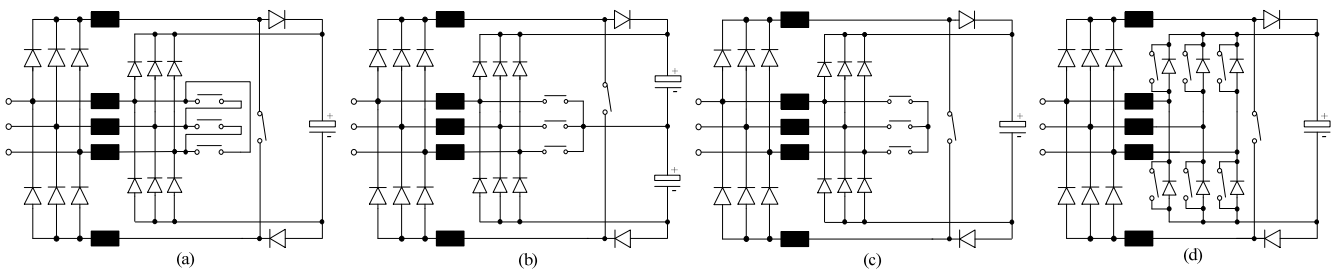

Fig. 1. Hybrid rectifier systems based on: (a) 2-level unidirectional delta-switch rectifier; (b) 3-level unidirectional T-type rectifier; (c) 2-level unidirectional wye-switch rectifier; and (d) 2-level bidirectional rectifier.

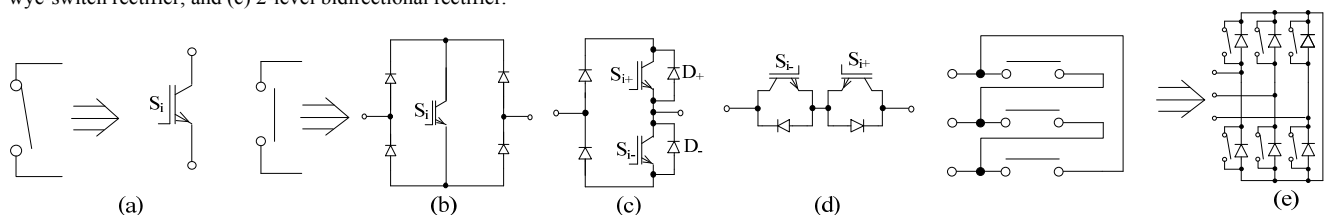

Fig. 2. Basic switch types: (a) unipolar switch; and bidirectional (current) and bipolar (voltage) switch employing (b) single active switch; (c) and (d) two active switches; and (e) 3-phase power module.

obtained by the combination of the currents drained for each rectifier unit, which doesn't necessarily display high power factor. Finally, hybrid rectifiers cannot be classified as active filters due to the fact that the self-commutated rectifier, in this case, processes high amounts of active power, while active filters are intended to process only reactive power [2].

In this paper, a novel, highly efficient 3-phase hybrid rectifier with controlled dc-link voltage, capable of providing close to sinusoidal shaped line currents is introduced. As shown in Fig. 3, the proposed ac-to-dc system is formed by the parallel connection of a controlled 3-phase diode bridge boost rectifier with a 3-phase unidirectional delta-switch rectifier.

This article is organized as follows. Section II presents the novel hybrid delta-switch rectifier, and the principle of its operation is discussed. Subsequently, for the rectifier design, analytical expressions for calculating the power components average and *rms* current ratings are given in Section III. In Section IV a suitable control method, able to handle a phase loss without changing the controller structure, is proposed. Additionally, an efficiency comparison between the proposed hybrid systems with other rectifier concepts, fully designed employing commercial components, is shown in Section V. Finally, in Section VI experimental results obtained with a unidirectional hybrid delta-switch rectifier prototype are presented to demonstrate the performance and feasibility of this solution.

II. THE HYBRID DELTA-SWITCH RECTIFIER

Fig. 1 shows four hybrid rectifiers suitable for shaping the line currents and also to control the DC-link voltage of the system. These converter concepts are constructed by the parallel connection of a controlled 3-phase diode bridge

boost rectifier with a 3-phase unity power factor boost-type rectifier. In Fig. 1(a) the self-commutated system is based on the 2-level unidirectional delta-switch converter technology (cf. [6]). While for the hybrid converter depicted in Fig. 1(b), 1(c) and 1(d), the 3-level unidirectional T-type rectifier, the 2-level unidirectional wye-switch topology and the 2-level bidirectional rectifier are employed, respectively.

The hybrid rectifier depicted in Fig. 1(a) and 1(b) are novel rectifier concepts introduced in this paper, while the converters depicted in Fig. 1(c) and 1(d) were previously proposed by [1] and [2], respectively.

Due to the fact that the power processed by a hybrid converter is shared between the integrating rectifier units, operation under higher efficiency and robustness can be accomplished when compared to a single self-commutated rectifier solution. In addition, in case of failure of one of the rectifier units, the other working structures can continue delivering power to the load at controlled DC-link voltage.

Fig. 3 shows a suitable circuit implementation of the proposed 2-level unidirectional hybrid delta-switch rectifier, where the sinusoidal shaped line currents, $i_{R,S,T}$, are formed by the sum of the currents of the combined rectifiers, $i_{LR,LS,LT}$ and $i_{DR,DS,DT}$. Correspondingly, the output current, i_o , is derived from the sum of the output current of each paralleled rectifier unit. In order to guarantee the commutation of the diode bridge rectifier at low frequency, the controlled dc-dc boost rectifier must operate in Continuous Conduction Mode (CCM). In contrast, the input currents of the delta-switch rectifier, $i_{DR,DS,DT}$, are controlled to allow high power factor operation.

For hybrid rectifiers employing a bidirectional (current) self-commutated converter, the high power factor operation can be theoretically achieved for any combination of power

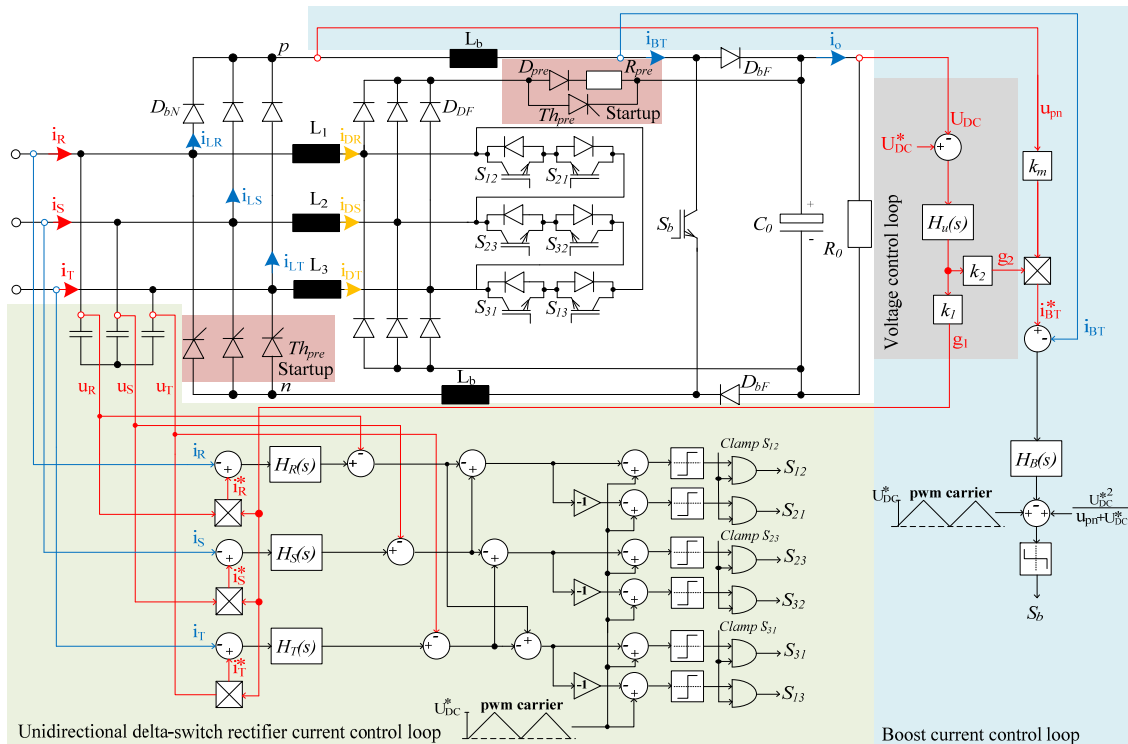

Fig. 3. Structure of the proposed unidirectional hybrid delta-switch rectifier and suitable control scheme.

shared between the compounding rectifiers. For example, if the line-commuted rectifier is set to process 100% of the output power, P_o , the bidirectional system, working as an active filter, will be able to compensate the current harmonics, attaining unity power factor operation.

Unidirectional hybrid rectifiers have conditional high power factor operation, which is reliant on the rated active power processed by the self-commuted converter, P_D . Due to the unidirectional power flow characteristic, the high line power quality operation can only be achieved if the instantaneous current absolute values of the line-commuted rectifier, $i_{LR,LS,LT}$, are smaller than the absolute values of the line current references, $i_{R,S,T}$. The simulation result showing this operation mode is presented in Fig. 4(a). The minimum rated output power processed by the active rectifier, P_D , which allows imposed sinusoidal line currents, is given by $P_D \approx 0.43P_o$. This operation condition is illustrated in Fig. 4(b). Finally, for $P_D < 0.43P_o$, the line currents become distorted as shown in Fig. 4(c).

For further evaluation of the hybrid delta-switch rectifier only high power factor operation will be considered, thus all analysis fulfills the operational condition $P_D \geq 0.43P_o$.

III. HYBRID RECTIFIER DESIGN CONSIDERATIONS

In this section some issues regarding the design and the practical realization of the unidirectional hybrid delta-switch rectifier will be discussed.

A. Startup

In order to limit the inrush current at the rectifier startup a pre-charge circuit, as shown in Fig. 3, is added to the delta-switch rectifier. Additionally, some diodes of the line-commuted rectifier are replaced by thyristors.

During the startup all thyristors and transistors are turned off and the inrush current is limited by the pre-charge circuit consisting of the serial connection of a diode, D_{pre} , and a resistor, R_{pre} . As soon as the DC-link capacitor C_o is charged to the peak value of the line-to-line voltages all thyristors are turned on and the current controller is finally enabled.

Unfortunately, during normal operation the pre-charge

thyristor, Th_{pre} , is located within the commutation path of the self-commuted rectifier. Consequently, not only the conduction/recovery power losses across this device are added to the system, but also the recovery losses of the fast diodes, D_{DF} , and turn-on losses of the active switches are increased. A parallel connection of thyristors could be used to reduce the on-resistance and parasitic influence of the current path.

B. Single-switch boost with splitting diodes and inductors

In order to avoid inappropriate current paths during some switching states, it is essential that the single-switch boost rectifier is implemented with splitting diodes, D_{bF} , and inductors, L_b . For example, as shown in Fig. 5, during the switch state where all active switches are turned off and the voltage vector lies in the sector $-30^\circ \dots 30^\circ$, the converter inductances L_b and $L_{1,2,3}$ are necessary to force the proper division of current between the redundant paths.

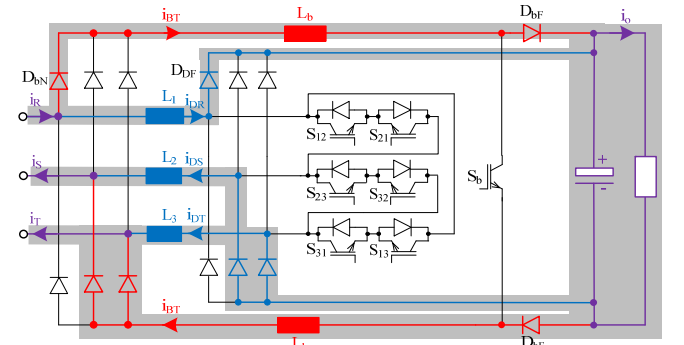

Fig. 5. Hybrid rectifier operation for switch-state where all active switches are turned off and the voltage vector lays in the sector $-30^\circ \dots 30^\circ$.

C. Power components design expressions

In Fig. 6, equations to determine the average and *rms* values of the current stresses on the power semiconductor components of a bridge-leg, as required for the dimensioning of the hybrid converter, are specified. The simple analytical expressions are given as functions of the modulation index, M , the output power, P_o , and the factor of active power processed by the self-commuted rectifier, α .

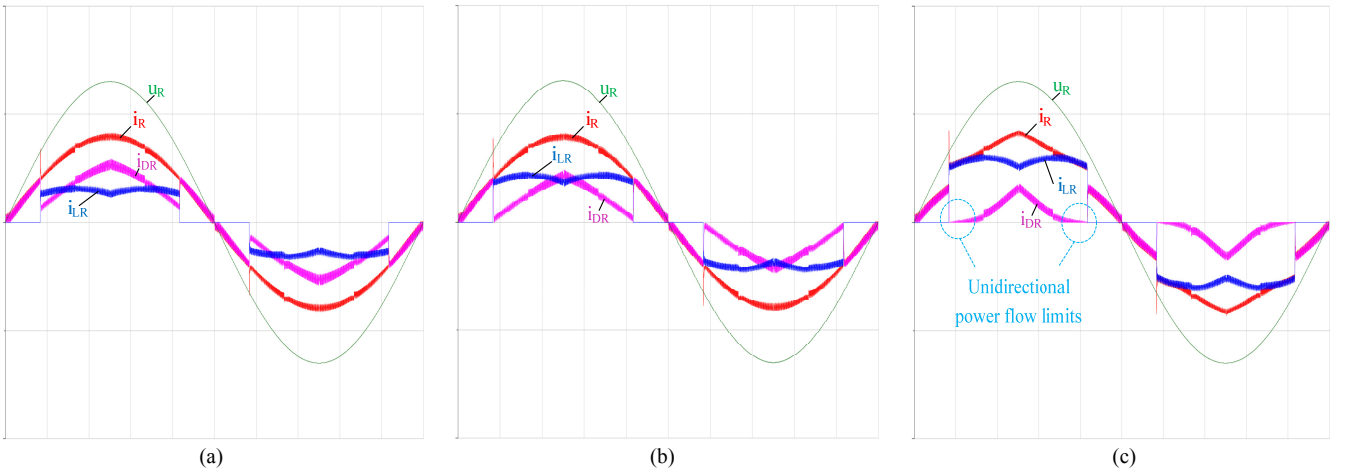

Fig. 4. Simulation results for unidirectional hybrid delta-switch rectifier for different operation modes: (a) ideal $P_D > 0.43P_o$; (b) unity power factor limit operation $P_D = 0.43P_o$; and (c) distorted operation $P_D < 0.43P_o$.

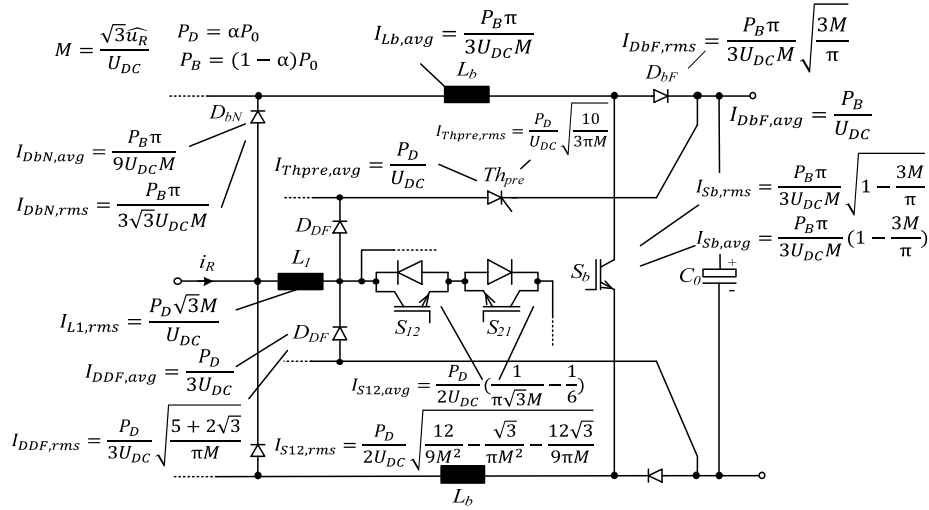

Fig. 6. Current stress on the power components of a bridge-leg of the unidirectional hybrid delta-switch rectifier.

IV. CONTROL STAGE OF THE HYBRID RECTIFIER

The structure of the proposed control scheme is illustrated in Fig. 3. The voltage control loop establishes the DC voltage regulation and the output power sharing between the combined rectifiers of the hybrid system, which is defined mainly by the ratio of the gains k_l and k_2 .

The line current references, $i_{R,S,T}^*$, are generated by multiplying the sensed mains voltages, $u_{R,S,T}$, by a reference conductance, g_l , which is defined by the superimposed output voltage controller, $H_u(s)$, rated by the established power loading sharing factor k_l . Together with a mains voltage feed-forward signal, the current controllers, $H_{R,S,T}(s)$, generate the required converter phase voltages. Subsequently, these signals are converted into line-to-line voltages. Finally, two independent PWM signals are generated guided by the clamping signals, derived from the grid voltages. The resulting clamping actions, considering all 60° space vector sectors, are shown in Table I. Note that “1” indicates that the corresponding active switch is turned on, “0” indicates the turn-off state, and *pwm* that the transistor is modulated by the current controller.

For the single-switch boost converter the current i_{BT} is sensed and compared to the reference current signal, i_{BT}^* , generated by multiplying the sensed rectified voltage by the conductance g_2 . The error signal is applied to the current compensator $H_B(s)$ and the PWM modulator, incorporating a feed-forward control loop, generates the gate signal of the boost switch. A similar control scheme is also suitable for the 2-switch boost converter, however the second switch controls the current at the bottom inductance.

Notice that by employing P-regulators for the controllers $H_{R,S,T}(s)$, the proposed control scheme becomes able to handle a phase loss operation without any change in the control structure being necessary. The simulation results of the unidirectional hybrid delta-switch rectifier operating close to the unity power factor limit, $\alpha \approx 0.45$, are compiled in Fig. 7 and 8. The converter specification presented in Table II is considered in this performance evaluation. The results

demonstrate that the line currents, $i_{R,S,T}$, can effectively follow the sinusoidal input voltages, $u_{R,S,T}$, even after load steps or during mains phase loss. The THD of the line currents for 10 kW operation is approximately 3.5%.

Table. I- PWM modulation with the required clamping actions.

Sector	S12	S21	S23	S32	S13	S31
$330^\circ-30^\circ$	pwm12	1	0	0	pwm13	1
$30^\circ-90^\circ$	0	0	pwm23	1	pwm13	1
$90^\circ-150^\circ$	1	pwm21	pwm23	1	0	0
$150^\circ-210^\circ$	1	pwm21	0	0	1	pwm31
$210^\circ-270^\circ$	0	0	1	pwm32	1	pwm31
$270^\circ-330^\circ$	pwm12	1	1	pwm32	0	0

Table. II- Unidirectional hybrid delta-switch rectifier specifications.

Input voltage, $u_{R,S,T}$:	230 Vrms
Input frequency, f_{in} :	50 Hz
Switching frequency, f_s :	50 kHz
DC-link voltage, U_{DC} :	800 V
Output power, P_o :	10 kW
Self-commt. rectifier active power, P_D :	4.5 kW
Output capacitor, C_o :	1.47 mF
DC inductor, L_b :	1 mH
Delta-switch rectifier inductors, $L_{1,2,3}$:	1 mH

V. COMPARATIVE EVALUATION OF RECTIFIERS

In order to quantify the feasibility of the proposed unidirectional hybrid delta-switch rectifier, an efficiency comparison between this system and other concepts shown in Fig. 9, is presented. The converter specifications considered in the analyses are: $P_o=10kW$, $u_{R,rms}=230V(50Hz)$, and $U_{DC}=800V$. The Infineon IGBTs 600V IKW30N60T and 1200V IKW25T120 are selected for the assessment and their loss characteristics are determined with an assembled test set-up. For the line-commuted and fast diodes, the devices DSP25-12A, APT30D120BG and APT30D60BG are used in the calculations.

For the hybrid systems the 2-switch boost converter is considered in the evaluation, as shown in Fig. 9(d) and 9(e). This circuit modification guarantees a better efficiency performance for high switching frequency operation. Additionally, each rectifier is designed to cope with fully specified power capability, however the calculations

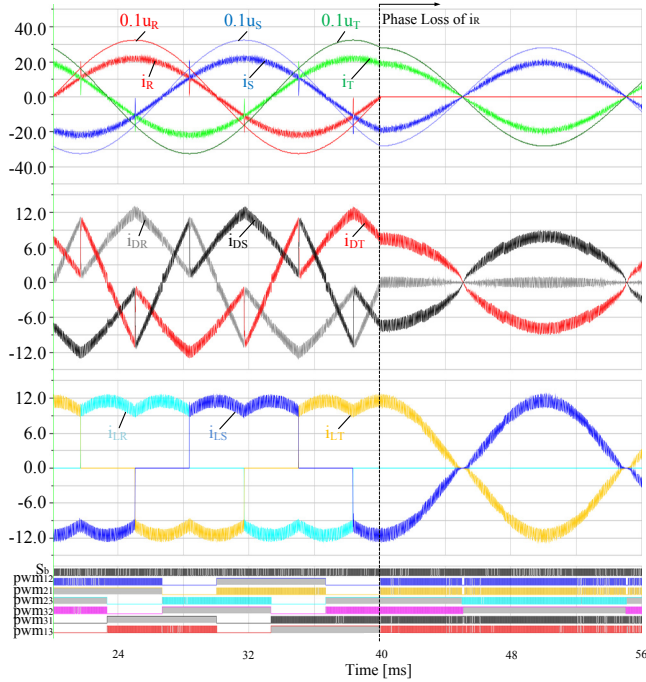

Fig. 7. Simulation results of the unidirectional hybrid delta-switch rectifier for mains phase loss operation.

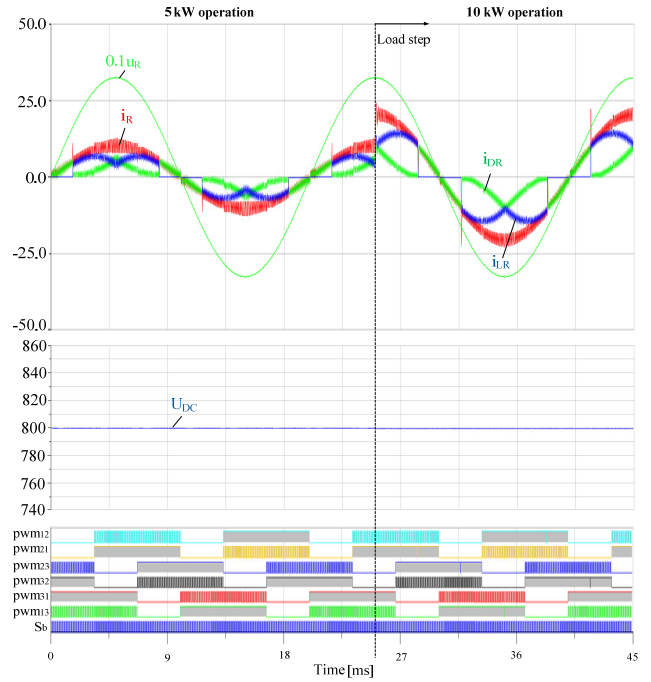

Fig. 8. Simulation results for load variation (from 5kW to 10kW).

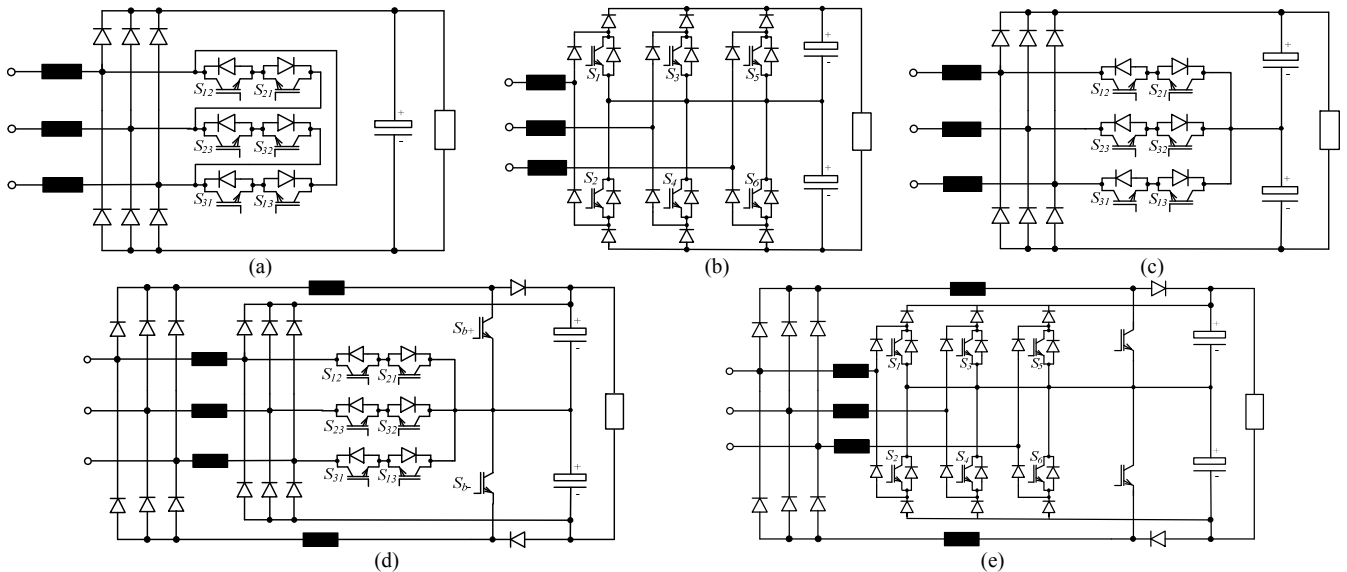

Fig. 9. 3-phase rectifier systems: active rectifier technologies: (a) 2-level delta-switch rectifier; (b) 3-level VIENNA 6-switch rectifier; (c) 3-level T-type converter; and new 3-level unidirectional hybrid based on: (d) T-type converter; and (e) VIENNA 6-switch rectifier;

consider that the rated active power processed by the self-commutated rectifier is $\alpha=0.43$. Finally, both rectifier structures are set to operate at the same switching frequency.

In Fig. 10 the pure semiconductor efficiency of the studied rectifiers is presented for operation in the switching frequency range of 5 kHz to 50 kHz. As can be seen, the new hybrid topologies can achieve higher efficiency than the single self-commutated rectifier solutions they are based on. In order to improve the loss performance of these systems the 2-switch boost topology could be set to operate at lower switching frequency than the self-commutated rectifier.

The 3-level hybrid converters constitute the natural choice for high switching frequency operation, while the 2-level hybrid would be better only for very low frequencies.

Among the single self-commutated rectifier solutions the 3-level VIENNA already constitutes the best solution for a switching frequency above 6 kHz. In fact, this converter is particularly suitable for high switching frequency operation because of the small increase in the switching losses. In contrast, the 2-level delta-switch rectifier displays very low conduction losses, thus it has superior performance for low switching frequency operation.

VI. EXPERIMENTAL EVALUATION

Fig. 11 shows a designed 5kW/72kHz ($U_{DC}=400V$) delta-switch rectifier used to assemble the proposed unidirectional hybrid delta-switch converter. The self-commutated system is air cooled and has a power to weight

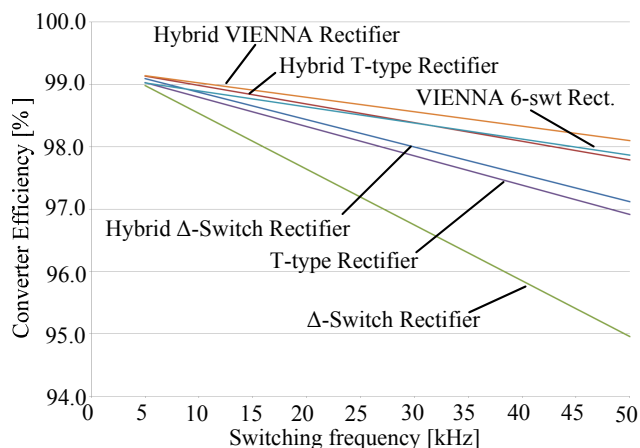

Fig. 10- Efficiency comparison between the different rectifiers employing commercial components.

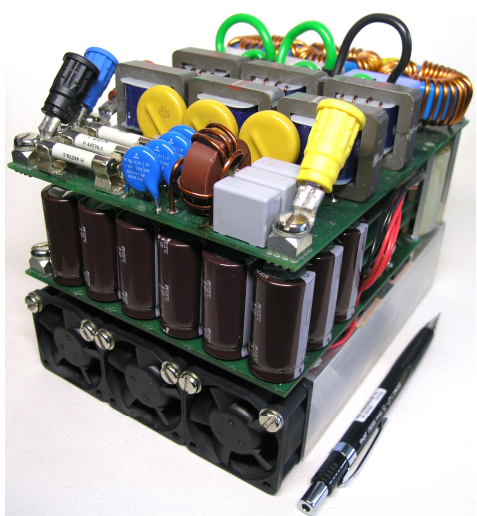

Fig. 11- Delta-switch rectifier prototype.

ratio of 1.32 kW/kg. The power density of this rectifier is 2.35kW/dm³. A digital signal processing board with a TI DSP and a Lattice FPGA is used to implement the control strategy shown in Fig. 3. Three inductors with inductance values of 326μH are employed. In total, eighteen 82μF/450V electrolytic capacitors are arranged in parallel.

The performance of the implemented unidirectional hybrid delta-switch rectifier can be seen in Fig. 12. Fig. 12(a) shows the main experimental waveforms for high power factor operation, which attest the feasibility of this new converter solution. Fig. 12(b) presents the experimental results when the rated power processed by the delta-switch rectifier is set to be below the unity power factor limit. In this case, as expected, the line current becomes distorted.

VII. CONCLUSIONS

This paper introduces a novel 3-phase hybrid rectifier assembled by the parallel connection of a 3-phase diode bridge boost rectifier with a 2-level unidirectional delta-switch rectifier. This system aims to take advantage of the commonly low power losses and high reliability of a diode based boost rectifier and also to benefit from the delta-rectifier capability of processing reactive power. Therefore, a highly efficient and reliable high power factor rectifier system with controlled dc-link voltage is constructed. An

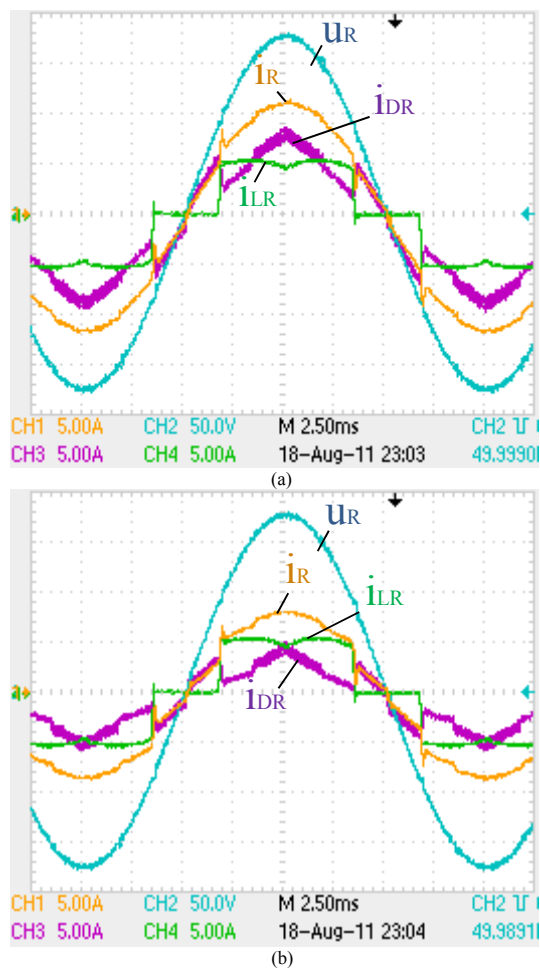

Fig. 12. Hybrid delta-switch rectifier experimental analysis: (a) high power factor operation; and (b) operation below the unity power factor limit. Ch1: line current (i_R), Ch2: mains voltage (u_R), Ch3: delta-switch rectifier current (i_{DR}), and Ch4: boost rectifier current (i_{LR}).

efficiency comparison between the the proposed hybrid delta-switch rectifier with other concepts derived from the new 3-level hybrid T-type or VIENNA converters and the single self-commutated converters, including the VIENNA 6-switch, delta-switch and T-type rectifiers is presented. Finally, experimental results obtained with a unidirectional hybrid delta-switch rectifier prototype are shown to demonstrate the performance and feasibility of this solution.

REFERENCES

- [1] R. L. Alves, C. H. Illa Font and I. Barbi, "Novel unidirectional hybrid three-phase rectifier system employing boost topology," in *Proc. of PESC 2005*, pp. 487-493, 2005.
- [2] C. H. Illa Font and I. Barbi, "A new high power factor bidirectional hybrid three-phase rectifier," in *Proc. of APEC 2006*, pp. 1300-1306, 2006.
- [3] M. D. Manjrekar, P. K. Steimer, and A. Lipo, "Hybrid multilevel power conversion system: a competitive solution for high power applications," *IEEE Trans. Ind. Appl.*, vol. 36, no. 3, Jun. 2000.
- [4] L. C. G. de Freitas, M. G. Simoes, C. A. Canesin, and L. C. de Freitas, "Programmable pfc based hybrid multipulse power rectifier for ultraclean power application," *IEEE Trans. Power Electron.*, vol. 21, no. 4, pp. 959-966, Jul. 2006.
- [5] R. L. Alves, and I. Barbi, "Analysis and implementation of a hybrid high-power-factor three-phase unidirectional rectifier," *IEEE Trans. Power Electron.*, vol. 24, no. 3, pp. 632-640, Mar. 2009.
- [6] M. Hartmann, J. Miniboeck, and J. W. Kolar, "A three-phase delta switch rectifier for more electric aircraft applications employing a novel pwm current control concept," in *Proc. of APEC 2009*, 2009.