



Power Electronic Systems
Laboratory

© 2018 IEEE

Proceedings of the 4th IEEE Argentina Biennial Congress (ARGENCON 2018), San Miguel de Tucuman, Argentina,
June 6-8, 2018

Three-Phase AC-DC Converters with Passive, Active and Hybrid Current Injection Circuits - Part II

M. Rivera,
D. Faundez,
J. W. Kolar,
P. Wheeler,
J. W. Riveros

Personal use of this material is permitted. Permission from IEEE must be obtained for all other uses, in any current or future media, including reprinting/republishing this material for advertising or promotional purposes, creating new collective works, for resale or redistribution to servers or lists, or reuse of any copyrighted component of this work in other works.



Eidgenössische Technische Hochschule Zürich
Swiss Federal Institute of Technology Zurich

Three-Phase AC-DC Converters with Passive, Active and Hybrid Current Injection Circuits - Part II

M. Rivera^{†1}, D. Faundez^{†2}, J. Kolar^{*3}, P. Wheeler^{‡4} and J.A. Riveros^{†5}

[†]*Faculty of Engineering, Universidad de Talca
Curico, CHILE*

¹marcoriv@utalca.cl

²dfaundez12@alumnos.utalca.cl

⁵jriveros@utalca.cl

^{*}*ETH Zurich*

Zurich, SWITZERLAND

³kolar@lem.ee.ethz.ch

[‡]*The University of Nottingham*

Nottingham, UK

⁴Pat.Wheeler@nottingham.ac.uk

Abstract—AC-DC Three-phase converters are highly well known for having enhanced power quality with unity displacement power factor, low total harmonic pollution on the AC side, and controllable DC output with unidirectional or bidirectional power flow. The second part of this paper presents a review of several three-phase AC-DC converters with active current injection circuits, including some hybrid configurations, detailing their respective topologies and characteristics.

Resumen— Los convertidores trifásicos CA-CC son muy conocidos por tener una calidad de potencia mejorada con factor de desplazamiento unitario del factor de potencia, baja distorsión armónica total en el lado de CA y salida CC controlada con flujo de potencia unidireccional o bidireccional. La segunda parte de este artículo presenta una revisión de varios convertidores trifásicos CA-CC con circuitos de inyección de corriente activa, incluyendo algunas configuraciones híbridas, detallando sus respectivas topologías y características.

I. INTRODUCTION

Three-phase AC-DC diode converters have been extensively employed because they are very simple and inexpensive, but at the expenses of input currents highly distorted and low displacement power factor. In order to solve these issues, different topologies have been proposed [1]. Passive filters, active filters and current controlled injection are common techniques to externally attenuate the current harmonics generated by rectifiers.

As shown in the first part of this paper, passive filters are connected between the rectifier and supply terminals (in series or shunt) to block or direct to ground the current harmonics generated by the rectifier. Series filters cause high impedance at the current harmonic frequencies. They may cause distortion to the rectifier input voltage harmonics, at the cost of physical size and components.

Shunt filters are parallel connected at the connection point of the supply and rectifier, creating a low impedance at the current frequencies and the harmonics tend to flow

towards the supply neutral through the shunt filter rather than through the supply. This filter only takes a small percentage of the full line current and the combination of the supply impedance along with filter can cause resonances that might affect the behavior of the rectifier or the supply.

Active filters supply either current or voltage harmonics on the AC side which are of equal amplitude and opposite phase to these generated by the non-linear load of the rectifier. It is widely used in industrial power systems and requires measurements of voltage and current waveforms. Suitable isolation should be provided.

Hybrid power filters correspond to combinations of active and passive filters. They were developed to overcome the above disadvantages and make active filtering methods more attractive from an economical and viability points of view.

Current control injection techniques involve the injection of a constant pattern variable amplitude current to the AC side of standard line commutated rectifiers to mitigate the line current distortions generated by the rectifiers.

AC-DC systems with improved source current quality could be developed as high-switching-frequency rectifiers systems or as passive multi-pulse rectifiers allowing an effective control of the output voltage and input side [2].

One solution is to include an extra converter (boost, buck, and buck-boost) which handles all the energy circulating through the converter, showing a good performance in different operation points (Fig. 1). The main problem of this alternative is that a costly controller is needed, and in addition, the efficiency is reduced because all the power is handled by the extra converter.

Another alternative is to replace the extra converter by a passive network as depicted in Fig. 1. This configuration does not process all the energy circulating through the converter but at the cost of huge passive elements reducing its efficiency. Additionally, the components of the passive network are adapted for a sole operation point, thus the accomplishment of the converter is not acceptable enough

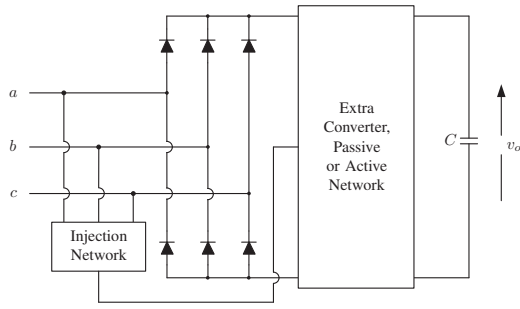

Fig. 1. Three-phase rectifier with an additional converter, passive or active network

under different load variations. To improve the source current, a special transformer is required in the injection network.

As it will be shown later, it is possible to find different three-phase rectifiers using these passive networks with different transformer configurations.

Recently an active network (which requires an inductor operating at high switching frequency) has been proposed to replace the passive network (Fig. 1), allowing for improved efficiency and fast dynamic response to different operation points. Similarly to the passive network, in this architecture the power processing is reduced.

The injection network is given by three bi-directional devices to select the path of the inductor current to be added to the corresponding phase. It is possible to find also some hybrid combinations of active networks where an injection network is formed for a special transformer.

In this paper, different topologies and characteristics for active current injection circuits and hybrid combinations will be presented and discussed.

II. AC/DC THREE-PHASE CONVERTER WITH HIGH POWER FACTOR

The main applications for these kind of converters are to provide DC power distribution systems in telecommunication, more electric aircraft, electric vehicle battery charging, high power lighting systems, and variable-speed AC drives.

A. Six-Pulse Rectifier with a Two-Level Three-Phase Active Power Filter and Interleaved DC-DC Buck Converter

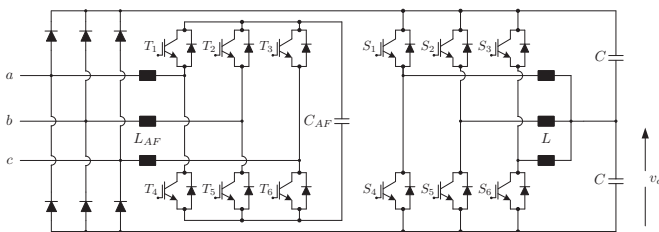

Fig. 2. Two-level three-phase active filter and interleaved DC-DC buck converter

The topology is formed by a three-phase full-bridge rectifier mixed with a two-level three-phase shunt active power filter (APF) all together with a set of interleaved DC/DC buck converters [3] (Fig. 2).

The main benefit of this configuration is the considerably small amount of power of the APF which is around 40%

of the total power required by the load. In presence of any breakdown in the APF, the converter could keep working, but not with a power factor correction capacity.

In Fig. 3 and Fig. 4 are presented the possible shunt active filters. For low grid voltage levels, the three-level configurations are not wide distributed due to the essentially abundant quantity of components and therefore the high cost. Nevertheless, three-level APFs comprise attractive alternatives for applications where efficiency at low weight/volume are mandatory issues.

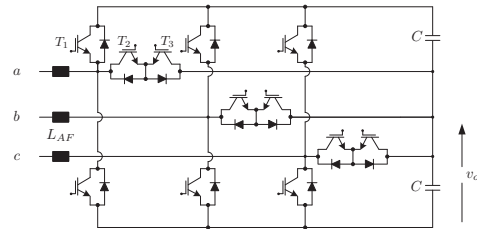

Fig. 3. Active filter based on the T-type voltage source power converter

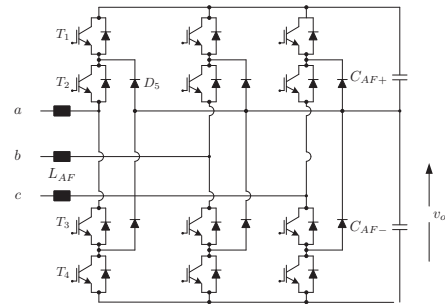

Fig. 4. Active filter based on the I-type (NPC) voltage source converter

B. Six-Pulse Rectifier with Active Third Harmonic Current Injection Rectifier with Single DC-DC Buck Converter

The converter shown in Fig. 5, consists of a three-phase high power factor active third harmonic injection rectifier and a series connected DC-DC buck-type converter [3].

The third harmonic injection rectifier replaces the APF system of the front-end converter, allowing sinusoidal input currents. The third harmonic injection rectifier illustrates an approximately low implementation force at the cost of an uncontrolled output voltage, presenting a six-pulse configuration.

The operation of the system with a DC-DC buck converter is interesting because only few active commutation devices in the source current path exit, leading to low conduction losses.

C. Three-Phase Three-Switch Buck-Type PFC Rectifier with LC Input Filter

This is another buck-type PFC rectifier configuration with working characteristics almost similar to the classical three-phase six-switch buck-type PFC rectifier with LC input filter (Fig. 6). This topology employs just three switching devices on the AC side of the bridge rectifier [4].

The main problem of this topology is the huge number of semiconductors in the current path, generating bigger conduction losses than the six-switch configuration (Fig. 7).

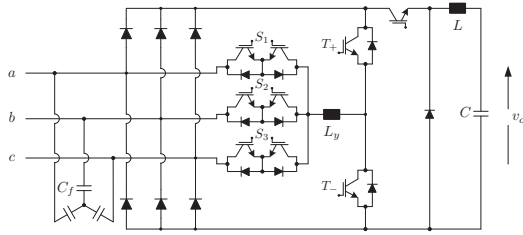

Fig. 5. Active third harmonic current injection rectifier with single DC-DC buck converter

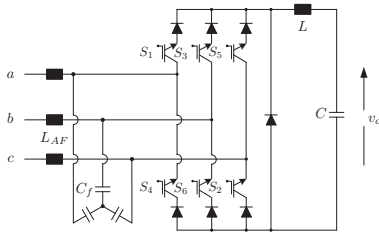

Fig. 6. Three-phase six-switch PFC rectifier with LC filter and freewheeling diode

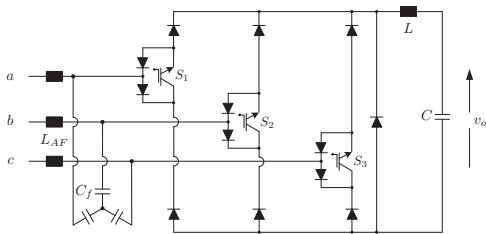

Fig. 7. Three-phase three-switch PFC rectifier with LC filter and freewheeling diode

D. Buck-Type Swiss Rectifier

The Swiss rectifier consists of a three-phase PFC rectifier mixing buck DC-DC topologies and an active third harmonic injection rectifier circuit [3]–[5].

The main benefits of this topology is that it is possible to control the output voltage with also a high power factor operation, achieving a remarkable efficiency compared to classical buck-type topologies (Fig. 8).

The converter form the currents in both the positive and negative active semiconductors in a proportional way to the two phase voltages employed in the output voltage creation of the diode bridge. While guaranteeing output voltage regulation, a sinusoidal source current waveform can be accomplished by injecting the difference between the currents in both positive and negative active semiconductor devices with the current smallest absolute voltage value via a current injection network, composed by the three bi-directional semiconductors commutating at twice the mains frequency.

The main applications for this converter are: power EV battery charging systems, future more electric aircraft, supplies for DC power distribution systems in telecommunication, high power lighting systems and variable speed AC drives.

E. Boost-Type Vienna Rectifier

This is a three-level three-phase PWM rectifier with three active devices and unidirectional power flow capability (Fig.

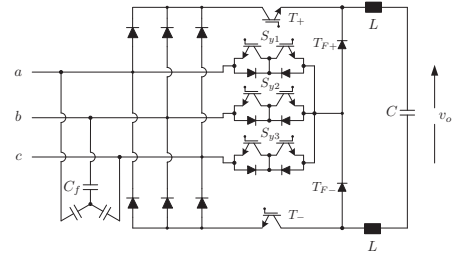

Fig. 8. Buck-type Swiss rectifier

9). A bi-directional switch is included in each leg of the line-commutated rectifier and the DC-link is split into two balanced portions.

This topology draws continuous currents from the supply, the complexity of the control system is reduced in contrast with other multi-level rectifiers topologies and the switching losses and device stresses are not severe.

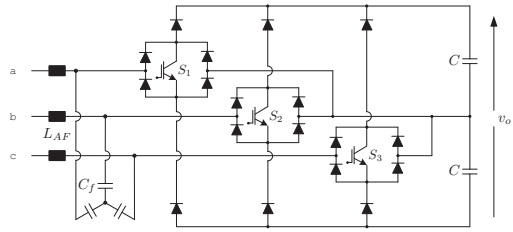

Fig. 9. Vienna Rectifier

F. Six-Pulse Rectifier with Three Bidirectional Switches

This circuit is formed by a diode rectifier and also uses three bi-directional switches connected between the split DC-link and the rectifier inputs (Fig. 10). The switches are synchronized with the third-harmonic ripple of the rectifier [6], [7].

The topology does not need connection to the neutral line of the AC system. As a consequence, the third harmonic component is naturally cancelled. The converter works with diminished source current, presents reduced harmonic pollution, without the need for any clamping circuit to avoid over-voltages along the active semiconductors during the turn-off commutation.

With this configuration high power factor is obtained along a lengthy output power range. The power circulating through the complementary switches is very little compared to the high power of the rectifier. As the auxiliary semiconductors operate at low frequency, fast-switching semiconductor devices are not necessary.

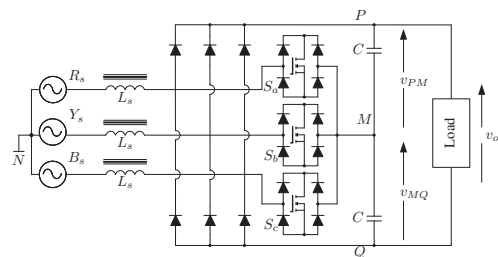

Fig. 10. Six-pulse rectifier with three bidirectional switches

III. HYBRID COMBINATIONS OF PASSIVE AND ACTIVE NETWORKS

A. 24-Pulse Rectifier with Harmonic Canceling Reactors

The 12-pulse rectifier is modified to produce 24-line current waveforms by using six bi-directional switches connected between the rectifier and the split DC-link [8]. The two three-level diode rectifiers are connected with three harmonic canceling reactors, obtaining a power converter with small size and lightweight (Fig. 11).

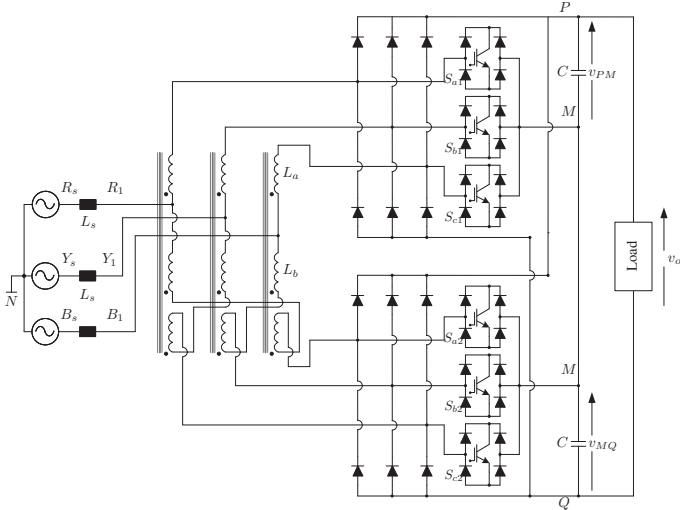

Fig. 11. Double three-level rectifier with harmonic canceling reactors

B. 12-Pulse Rectifier with Active Interphase Reactors

Two configurations have been proposed in [9], [10] where the converter consists of a 12-pulse diode rectifier with an active interphase reactor, obtaining almost sinusoidal input currents (Fig. 12 and Fig. 13).

These sinusoidal source currents are obtained due to the injection of a triangular current into the interphase reactor. The triangular current injected into the secondary winding of the interphase reactor produces nearly sinusoidal source currents.

The first scheme employs a Δ -Y isolation transformer (Fig. 14). The interphase reactor and the line impedances allow equal current sharings. The controlled active current triangular shaped is added into the secondary winding of the interphase reactor.

In the second alternative an autotransformer is used to obtain 30° phase displacement in the two diode rectifiers. Two interphase reactors are required because there is not electrical isolation. With these topologies fifth and seventh harmonics are naturally mitigated.

C. 12-Pulse Line Interphase Transformer (LIT) Rectifier with Integrated Single-Switch or Two-Switch Boost-Type Output Stage

In [11], [12] three different hybrid topologies based on 12-pulse line interphase transformer rectifier systems have been presented which are formed by a DC-DC boost-type converter with one (Fig. 15) or two switches (Fig. 16 and Fig. 17).

This stage allows to maintain a constant output voltage irrespective of power variations or line voltage. The topology

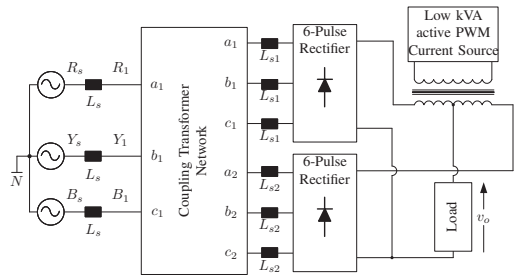

Fig. 12. 12-pulse rectifier with active interphase reactors (Alternative I)

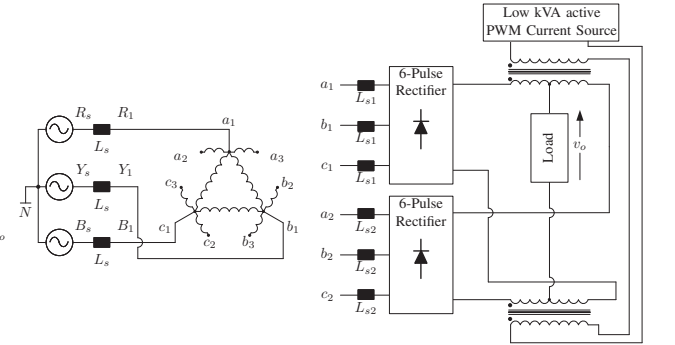

Fig. 13. 12-pulse rectifier with active interphase reactors (Alternative II)

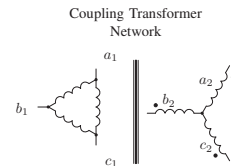

Fig. 14. Coupling transformer network of the 12-pulse rectifier with active interphase reactors

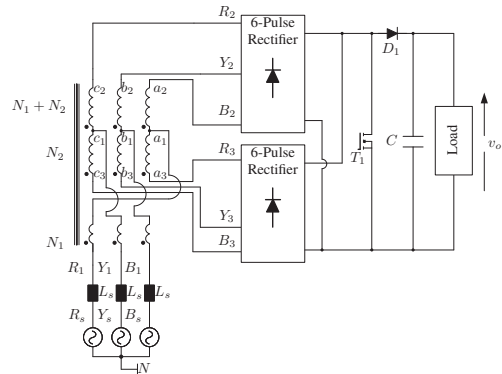

Fig. 15. Three-phase hybrid 12-pulse boost-type rectifier with single-switch topology (SSHR)

with the two switches presents higher efficiency and higher power factor than the single-switch topology.

IV. CONCLUSION

In the second part of this paper, the most popular and well known three-phase AC-DC power converters with active current injection circuits and hybrid combinations have been presented. The main characteristics, advantages and disadvantages have been detailed providing a state of the art of the several alternatives for AC-DC power conversion.

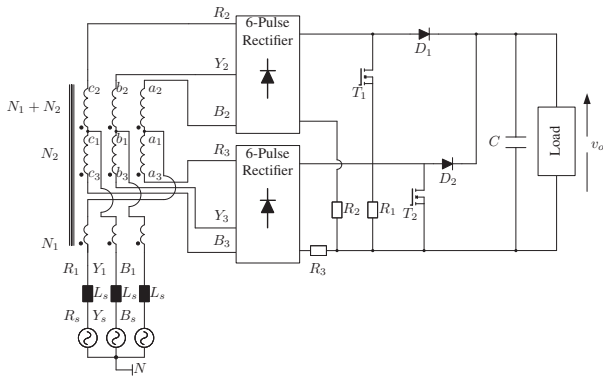

Fig. 16. Three-phase hybrid 12-pulse boost-type rectifier with two switch topology (TSHR)

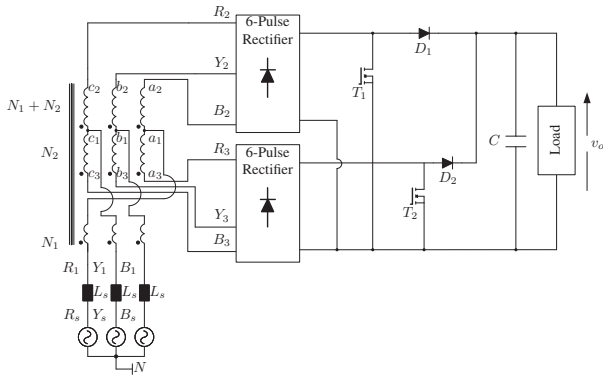

Fig. 17. New three-phase hybrid 12-pulse boost-type LIT rectifier with two switch topology

ACKNOWLEDGMENT

The authors would like to thank the financial support of FONDECYT Regular 1160690 and Postdoctoral 3170014 Research Projects as well as MEC Project 80150056.

REFERENCES

- [1] N. Vazquez, H. Rodriguez, C. Hernandez, E. Rodriguez, and J. Arau, "Three-phase rectifier with active current injection and high efficiency," *Industrial Electronics, IEEE Transactions on*, vol. 56, no. 1, pp. 110–119, 2009.
- [2] J. Kolar and H. Ertl, "Status of the techniques of three-phase rectifier systems with low effects on the mains," in *Telecommunication Energy Conference, 1999. INTELEC '99. The 21st International*, 1999, pp. 16 pp.–.
- [3] T. Soeiro, T. Friedli, and J. Kolar, "Three-phase high power factor mains interface concepts for electric vehicle battery charging systems," in *Applied Power Electronics Conference and Exposition (APEC), 2012 Twenty-Seventh Annual IEEE*, 2012, pp. 2603–2610.
- [4] T. B. Soeiro, T. Friedli, and J. W. Kolar, "Design and implementation of a three-phase buck-type third harmonic current injection pfc rectifier sr," *Power Electronics, IEEE Transactions on*, vol. 28, no. 4, pp. 1608–1621, 2013.
- [5] T. Soeiro, T. Friedli, and J. Kolar, "Swiss rectifier - a novel three-phase buck-type pfc topology for electric vehicle battery charging," in *Applied Power Electronics Conference and Exposition (APEC), 2012 Twenty-Seventh Annual IEEE*, 2012, pp. 2617–2624.
- [6] E. Mehl and I. Barbi, "An improved high power factor and low cost three-phase rectifier," in *Applied Power Electronics Conference and Exposition, 1995. APEC '95. Conference Proceedings 1995., Tenth Annual*, no. 0, 1995, pp. 835–841 vol.2.
- [7] —, "An improved high-power factor and low-cost three-phase rectifier," *Industry Applications, IEEE Transactions on*, vol. 33, no. 2, pp. 485–492, 1997.
- [8] K. Oguchi, G. Maeda, N. Hoshi, and T. Kubata, "Coupling rectifier systems with harmonic cancelling reactors," *Industry Applications Magazine, IEEE*, vol. 7, no. 4, pp. 53–63, 2001.

- [9] S. Choi, P. Enjeti, H. Lee, and I. Pitel, "A new active interphase reactor for 12-pulse rectifiers provides clean power utility interface," in *Industry Applications Conference, 1995. Thirtieth IAS Annual Meeting, IAS '95., Conference Record of the 1995 IEEE*, vol. 3, 1995, pp. 2468–2474 vol.3.
- [10] S. Choi, P. Enjeti, H.-H. Lee, and I. Pitel, "A new active interphase reactor for 12-pulse rectifiers provides clean power utility interface," *Industry Applications, IEEE Transactions on*, vol. 32, no. 6, pp. 1304–1311, 1996.
- [11] K. Mino, G. Gong, and J. Kolar, "Novel hybrid 12-pulse line interphase transformer boost-type rectifier with controlled output voltage," in *Power Electronics and Motion Control Conference, 2004. IPEMC 2004. The 4th International*, vol. 2, 2004, pp. 924–931 Vol.2.
- [12] —, "Novel hybrid 12-pulse boost-type rectifier with controlled output voltage," *Aerospace and Electronic Systems, IEEE Transactions on*, vol. 41, no. 3, pp. 1008–1018, 2005.